



1991

BMW 325i

Electrical

Troubleshooting

Manual

BMW of North America, Inc.
Woodcliff Lake, New Jersey

FOREWORD

In the interests of continuing technical development work we reserve the right to modify designs and equipment.

Printed in USA

©Copyright BMW of North America, Inc.

Not to be reproduced wholly or in part
without written permission of BMW of
North America, Inc.

PN 91 00 0 000 004

**1991
BMW 325i
Electrical
Troubleshooting
Manual**

CONTENTS

Index	2
How To Use This Manual	3
Wire Size Conversion Chart	3
Symbols	4
Systematic Troubleshooting	6
Connector Views	8500-0
Power Distribution Box	0670-0
Fuse Data	0670-1
Component Location Chart	9000-0
Component Location Views	7000-0
Splice Location Views	8000-0

The purpose of this manual is to show electrical schematics in a manner that makes electrical troubleshooting easier. Electrical components which work together are shown together on one schematic. The Wiper-Washer schematic, for example, shows all of the electrical components in one diagram. At the top of the page is the fuse (positive) that powers the circuit. The flow of current is shown through all wires, connectors, switches, and motors to ground (negative) at the bottom of the page.

Within the schematic, all switches and sensors are shown "at rest," as though the Ignition Switch were off. For identification, component names are underlined and placed next to or above each component. Notes are included, describing how switches and other components work.

The power distribution schematic shows the current feed through all the connections from the Battery and Alternator to each fuse and the Ignition and Light Switches. If the Power Distribution schematic is combined with any other circuit schematic, a complete picture is made of how that circuit works. The Ground Distribution schematics show how several circuits are connected to common grounds.

All wiring between components is shown exactly as it exists in the vehicle; however, the wiring is not drawn to scale. To aid in understanding electrical operation, wiring inside complicated components has been simplified. The "Solid State" label designates electronic components.

WIRE SIZE CONVERSION CHART	
METRIC (CROSS-SECTIONAL AREA IN MM ²)	AWG (AMERICAN WIRE GAUGE)
.5	20
.75	18
1	16
1.5	14
2	14
2.5	12
4	10
6	8
8	8
16	4
20	4
25	2
32	2

WIRE INSULATION	
ABBREVIATIONS	COLOR
BK	BLACK
BR	BROWN
RD	RED
YL	YELLOW
GN	GREEN
BU	BLUE
VI	VIOLET
GY	GRAY
WT	WHITE
PK	PINK
OR	ORANGE

4 SYMBOLS



ENTIRE COMPONENT SHOWN



PART OF A COMPONENT SHOWN

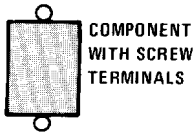

COMPONENT WITH SCREW TERMINALS



SOLID STATE (INCLUDES ONLY ELECTRONIC PARTS)

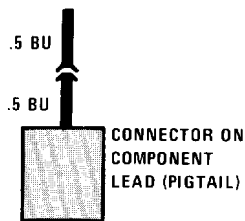

CONNECTOR ON COMPONENT LEAD (PIGTAIL)

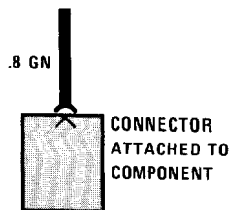

CONNECTOR ATTACHED TO COMPONENT

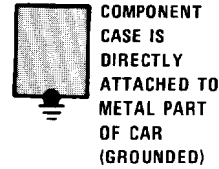

COMPONENT CASE IS DIRECTLY ATTACHED TO METAL PART OF CAR (GROUNDED)

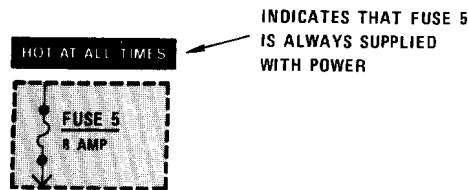

INDICATES THAT FUSE 5 IS ALWAYS SUPPLIED WITH POWER

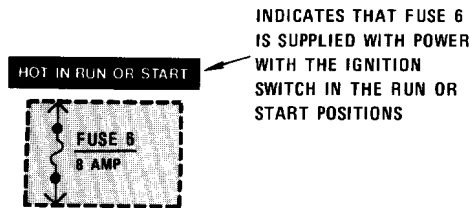

INDICATES THAT FUSE 6 IS SUPPLIED WITH POWER WITH THE IGNITION SWITCH IN THE RUN OR START POSITIONS

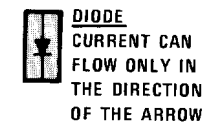
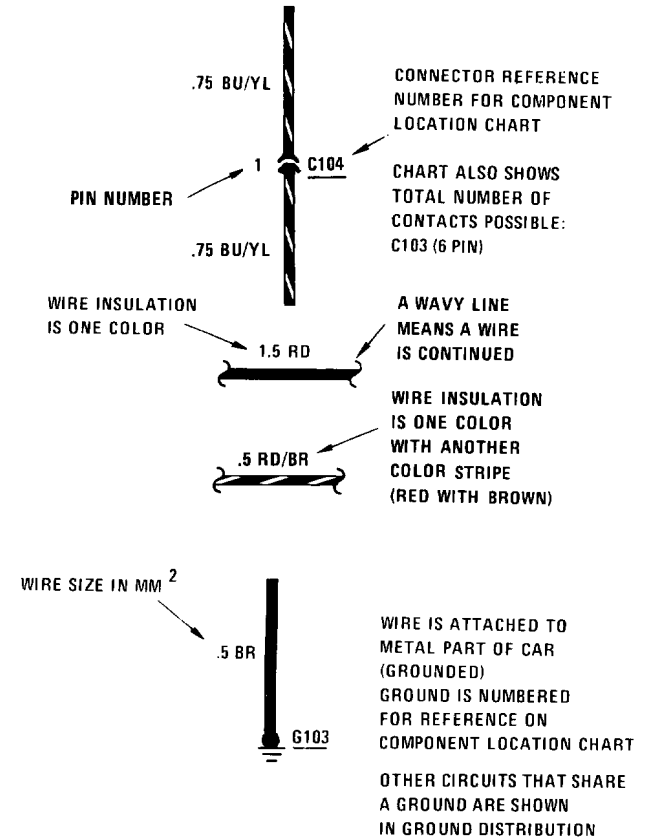
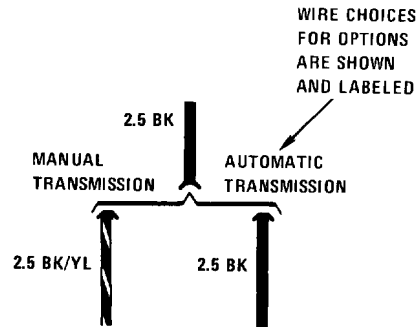

DIODE CURRENT CAN FLOW ONLY IN THE DIRECTION OF THE ARROW

CIRCUIT REFERENCE - A WIRE WHICH CONNECTS TO ANOTHER CIRCUIT



ACTIVE CHECK CONTROL

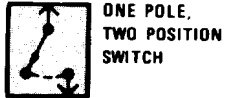

ONE POLE,
TWO POSITION
SWITCH

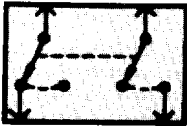

SWITCHES THAT
MOVE TOGETHER
DASHED LINE SHOWS
A MECHANICAL
CONNECTION
BETWEEN SWITCHES

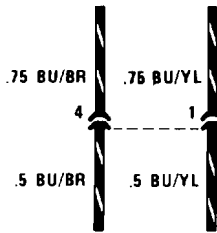

TWO CONNECTIONS
(PINS) IN THE SAME
CONNECTOR

DASHED LINE SHOWS
PARTS OF THE
SAME CONNECTOR

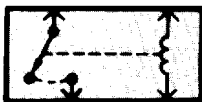

WHEN COIL IS
ENERGIZED, SWITCH
IS PULLED CLOSED

RELAY SHOWN
WITH NO
CURRENT
FLOWING
THROUGH
COIL



RESISTOR ACROSS COIL
IS FOR NOISE
SUPPRESSION

RELAY SHOWN
WITH RESISTOR
ACROSS COIL

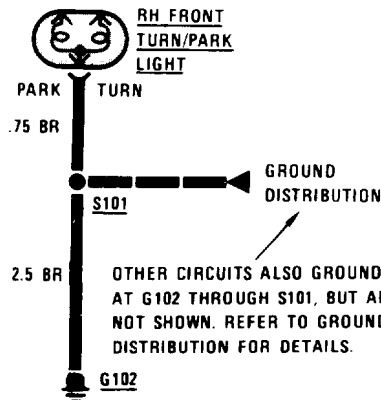

LIGHT
EMITTING
DIODE



INDUCTIVE
SENSOR

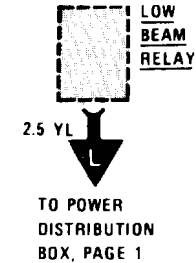
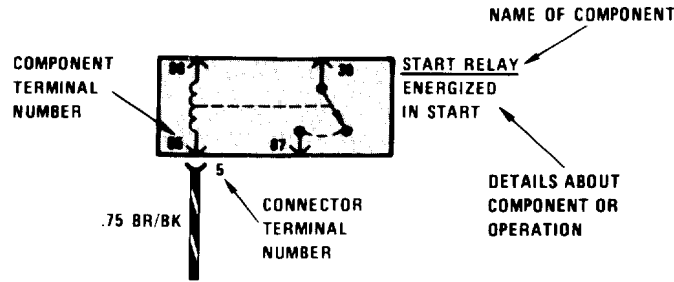

CURRENT PATH
IS CONTINUED
AS LABELED.
THE ARROW SHOWS
DIRECTION OF CURRENT
FLOW AND IS REPEATED
WHERE CURRENT
PATH CONTINUES.

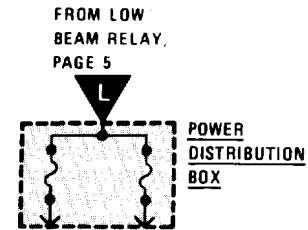
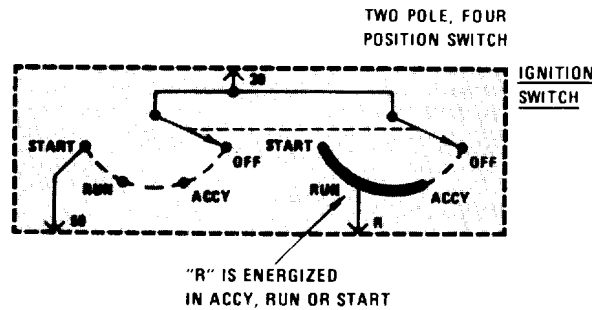

6 SYSTEMATIC TROUBLESHOOTING

TROUBLESHOOTING PROCEDURE

1. Verify the Problem

Operate the problem circuit to check the accuracy of the complaint. Note the symptoms of the inoperative circuit.

2. Analyze the Problem

Refer to the schematic of the problem circuit in the ETM. Determine how the circuit is supposed to work by tracing the current path(s) from the power feed through the circuit components to ground. Then based on the symptoms you noted in step 1 and your understanding of circuit operation, identify one or more possible causes of the problem.

3. Isolate the Problem

Make circuit tests to prove or disprove the preliminary diagnosis made in step 2. Keep in mind that a logical simple procedure is the key to efficient troubleshooting. Test for the most likely cause of failure first. Try to make tests at points which are easily accessible.

4. Repair the Problem

Once the specific problem is identified, make the repair using the proper tools and safe procedures.

5. Check the Problem

Operate the circuit to check for satisfactory circuit operation. Good repair practice calls for rechecking all circuits you have worked on.

TROUBLESHOOTING TOOLS

Isolating the problem (Step 3 of TROUBLESHOOTING PROCEDURES) requires the use of a **voltmeter** and/or **ohmmeter**. A voltmeter measures voltage at selected points in a circuit. An ohmmeter measures a circuit's resistance to current flow. It has an internal battery that provides current to the circuit under test. Disconnect the car battery when using an ohmmeter because the battery voltage will cause the ohmmeter to give false readings. Also, do not use an ohmmeter on solid-state components. The voltage that the ohmmeter applies to the circuit could damage these components.

TROUBLESHOOTING TESTS

Voltage Test

This test measures voltage in a circuit. By taking measurements at several points (terminals or connectors) along the circuit, you can isolate the problem.

To take a voltage measurement, connect the negative lead of the voltmeter to the battery's negative terminal or other known good ground. Then connect the positive lead of the voltmeter to the point you want to test. The voltmeter will measure the voltage present at that point in the circuit.

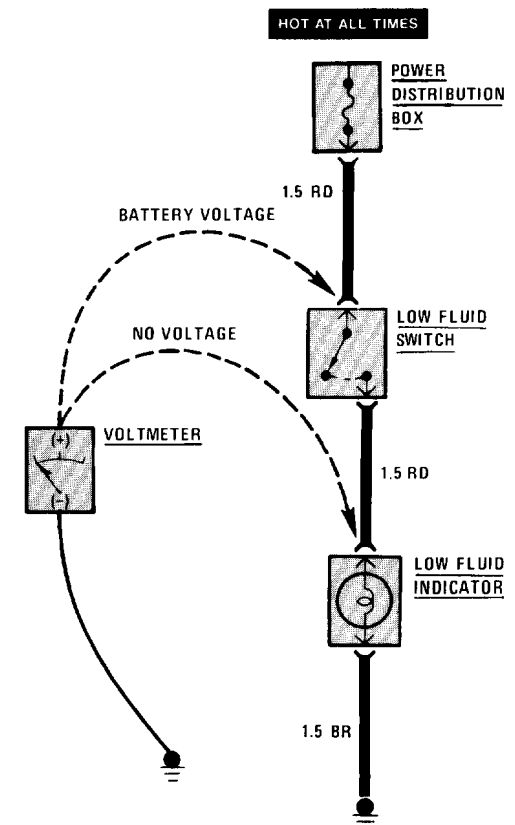

Voltage Test

Voltage Drop Test

Wires, connectors, and switches are designed to conduct current with a minimum loss of voltage. A voltage drop of more than one volt indicates a problem.

To test for voltage drop, connect the voltmeter leads to connectors at either end of the circuit's suspected problem area. The positive lead should be connected to the connector closest to the power source. The voltmeter will show the voltage drop between these two points.

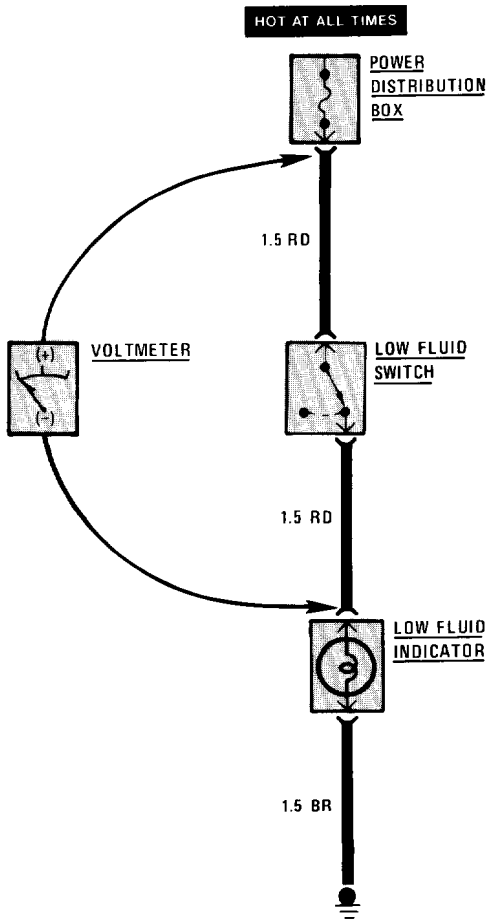

Voltage Drop Test

Continuity Test

To perform a continuity test, first disconnect the car battery. Then adjust the ohmmeter to read zero while holding the leads together. Connect the ohmmeter leads to connector or terminals at either end of the circuit's suspected problem area. The ohmmeter will show the resistance across that part of the circuit.

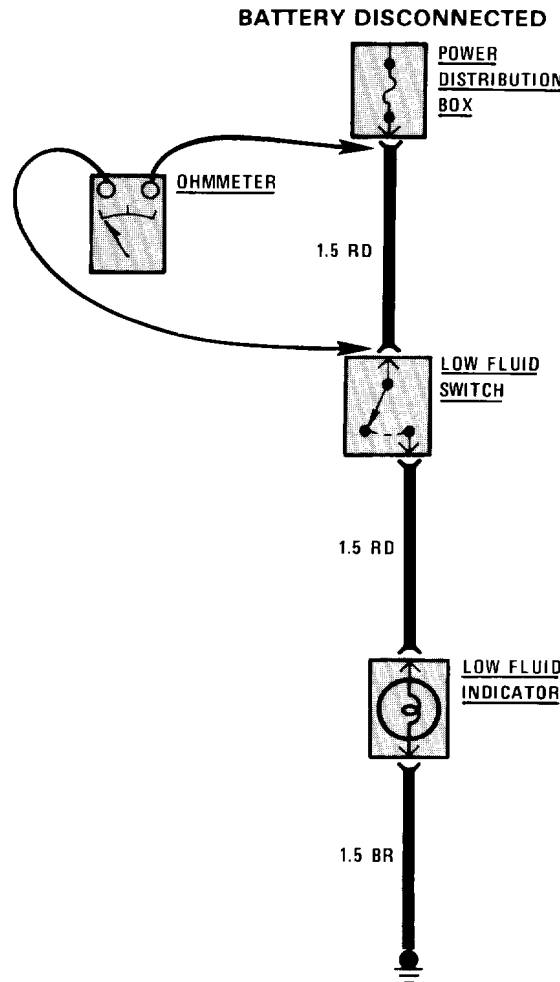

Continuity Test

Short Test Using Voltmeter

Remove the blown fuse and disconnect the load. Connect the voltmeter leads to the fuse terminals. The positive lead should be connected to the terminal closest to the power source.

Starting near the POWER DISTRIBUTION BOX, move the wire harness back and forth and watch the voltmeter reading. If the voltmeter registers a reading, there is a short to ground in the wiring. Somewhere in the area of the harness being moved, the wire insulation is worn away and the circuit is grounding.

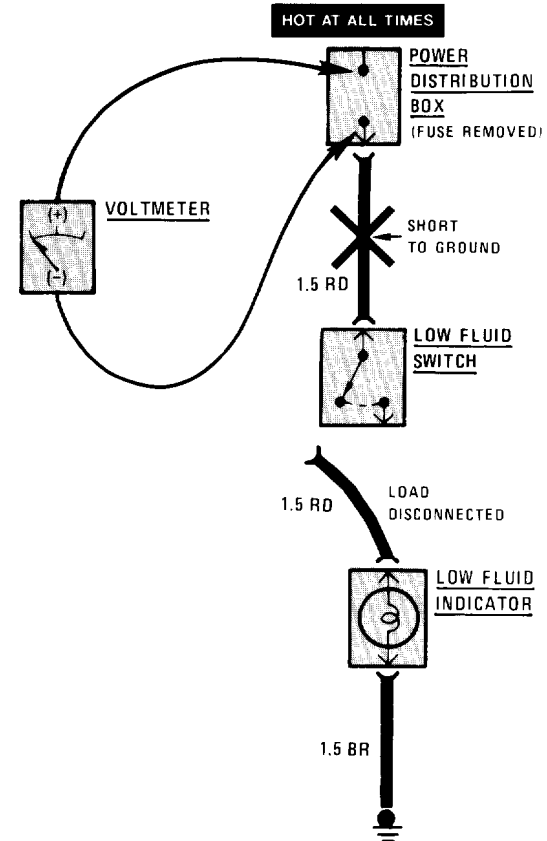

Short Test Using Voltmeter

8 SYSTEMATIC TROUBLESHOOTING

Short Test Using Ohmmeter

Disconnect the battery. Adjust the ohmmeter to read zero while holding the leads together. Remove the blown fuse and disconnect the load. Connect one lead of the ohmmeter to the fuse terminal that is closest to the load. Connect the other lead to a known good ground.

Starting near the POWER DISTRIBUTION BOX, move the wire harness back and forth and watch the ohmmeter reading. Low or no resistance indicates a short to ground in the wiring. Infinitely high resistance indicates no short.

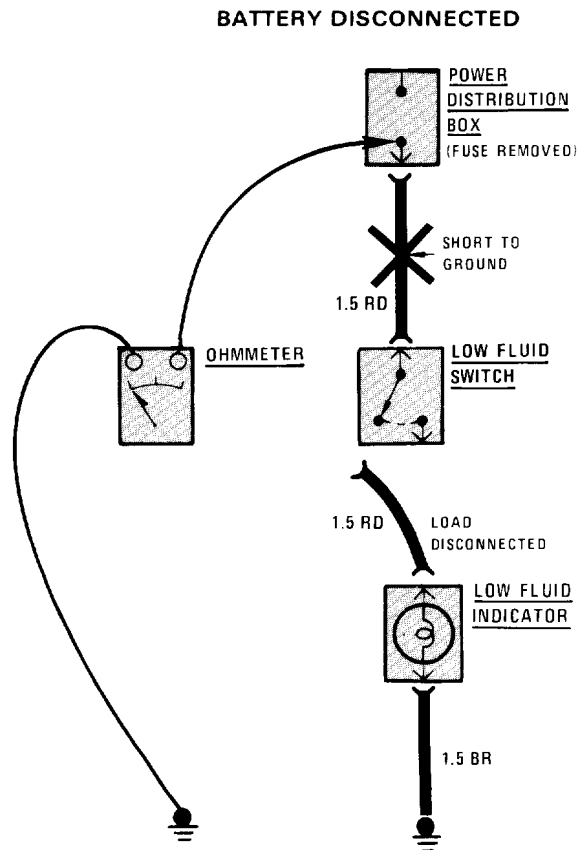

Short Test Using Ohmmeter

FUSE DETAILS: FUSE 10

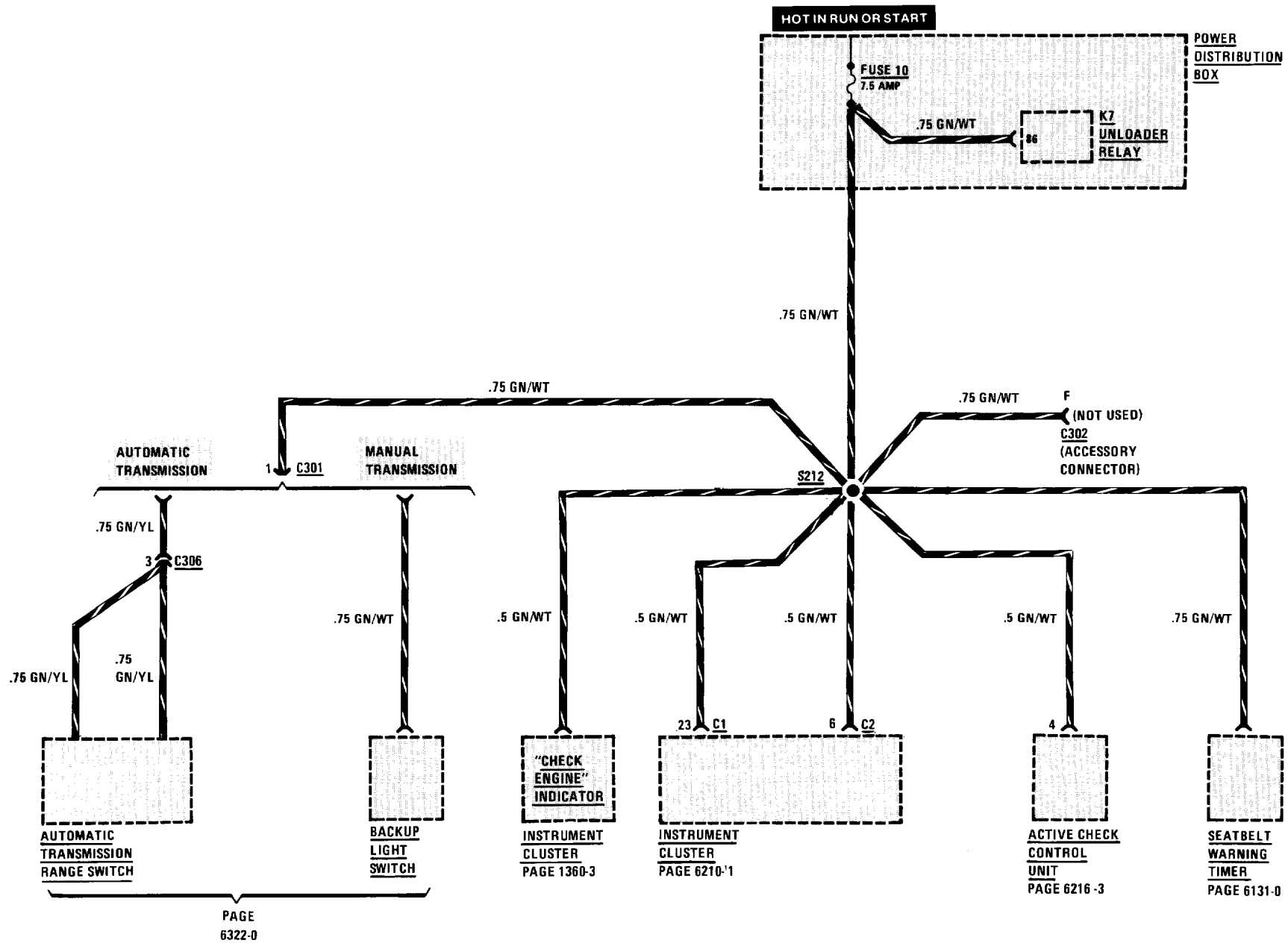

6300-0 LIGHT SWITCH DETAILS

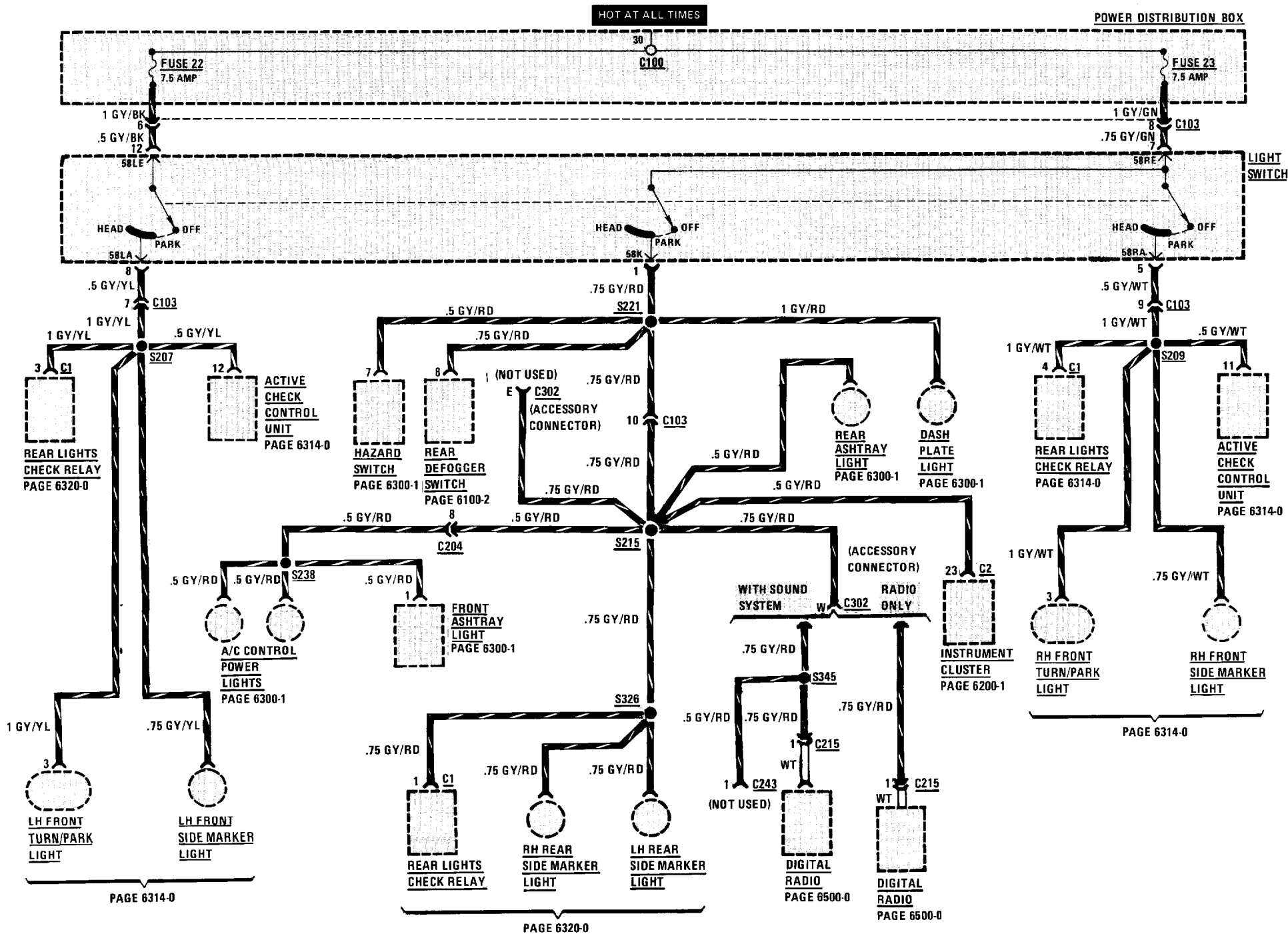

6314-0 PARK/TAIL/FRONT MARKER LIGHTS

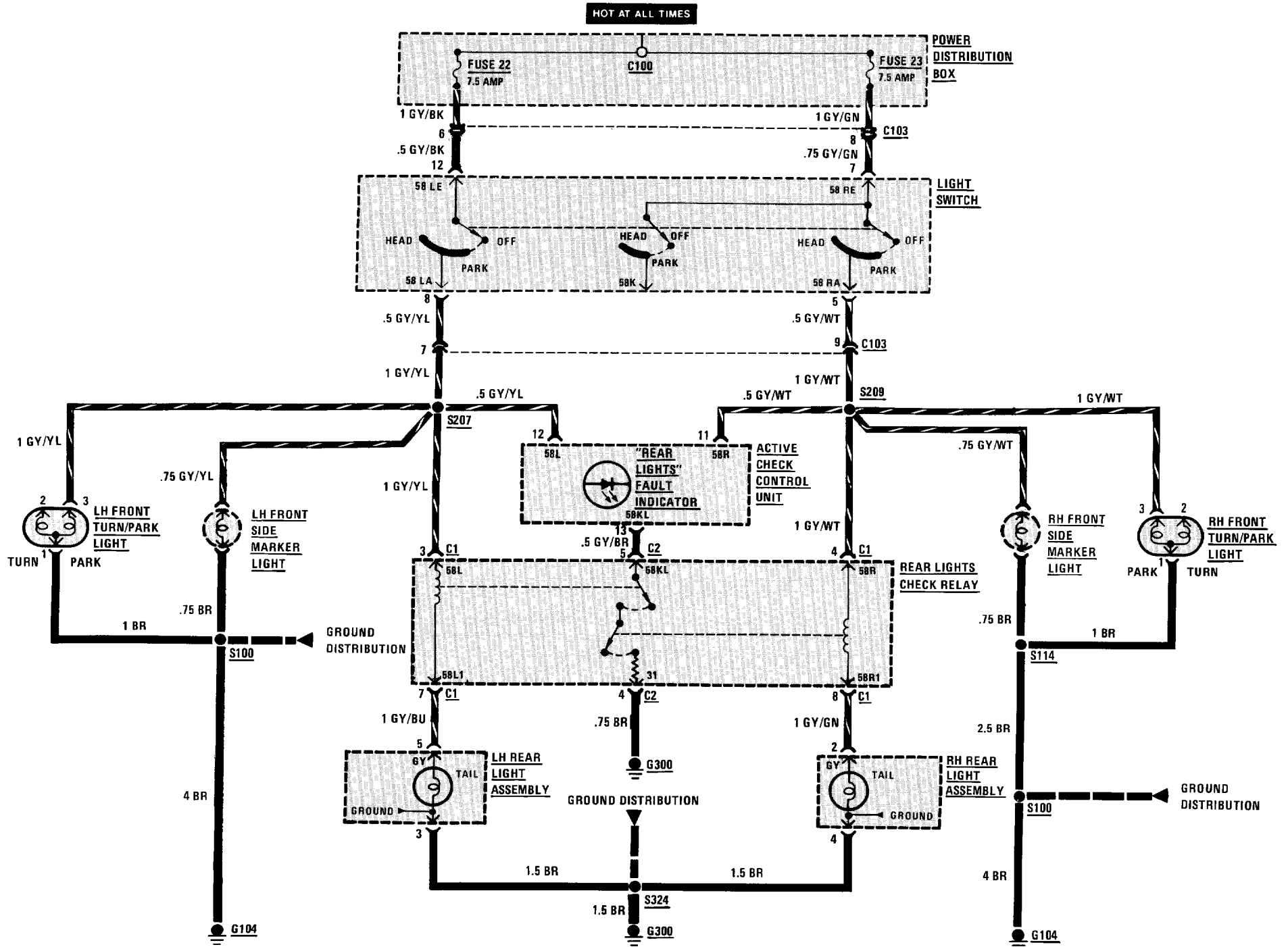

8000-0 SPLICE LOCATION VIEWS

INDEX

This index lists all the splices in the vehicle, the harness location of each splice, and the page on which each splice appears. The drawings after the index show how the harnesses are routed through the vehicle and the location of the splices on the harness.

SPLICE	HARNESS	PAGE NUMBER	SPLICE	HARNESS	PAGE NUMBER
S100	MAIN	8000-2	S224	MULTI-FUNCTION	NOT SHOWN
S101	ENGINE	8000-3		CLOCK	
S104	ENGINE	8000-3	S225	MULTI-FUNCTION	NOT SHOWN
S105	ENGINE	8000-3		CLOCK	
S106	ENGINE	8000-3		A/C	NOT SHOWN
S107	ENGINE	8000-3	S226	A/C	NOT SHOWN
S108	ENGINE	8000-3	S228	CRUISE CONTROL	NOT SHOWN
S109	ENGINE	8000-3		A/C	NOT SHOWN
S110	A/C	NOT SHOWN	S229	A/C	NOT SHOWN
S111	ENGINE	8000-3	S230	MAIN	8000-2
S112	ENGINE	8000-3	S231	MAIN	8000-2
S113	ENGINE	8000-3	S232	MAIN	8000-2
S114	MAIN	8000-2	S233	MAIN	8000-2
S115	MAIN	8000-2	S234	MAIN	8000-2
S116	MAIN	8000-2	S235	MAIN	8000-2
S118	MAIN	8000-2	S238	MAIN	NOT SHOWN
S119	MAIN	8000-2	S239	MAIN	8000-2
S201	ON-BOARD COMPUTER	8000-6	S240	A/C	NOT SHOWN
S202	ON-BOARD COMPUTER	8000-6	S241	MAIN	8000-2
S207	MAIN	8000-2	S250	A/C	NOT SHOWN
S209	MAIN	8000-2	S251	A/C	NOT SHOWN
S210	MAIN	8000-2	S252	A/C	NOT SHOWN
S211	MAIN	8000-2	S260	MAIN	8000-2
S212	MAIN	8000-2	S300	DOOR	8000-4
S213	MAIN	8000-2	S301	DOOR	8000-4
S215	MAIN	8000-2	S302	DOOR	8000-4
S219	INSTRUMENT PANEL	8000-5	S303	DOOR	8000-4
S221	INSTRUMENT PANEL	8000-5	S304	DOOR	8000-4
S223	CRUISE CONTROL	NOT SHOWN	S305	DOOR	8000-4
			S306	INSTRUMENT PANEL	8000-5
			S307	INSTRUMENT PANEL	8000-5
			S309	DOOR	8000-4
			S310	MAIN	8000-2

8000-2 SPLICE LOCATION VIEWS

MAIN HARNESS SPLICE LOCATIONS

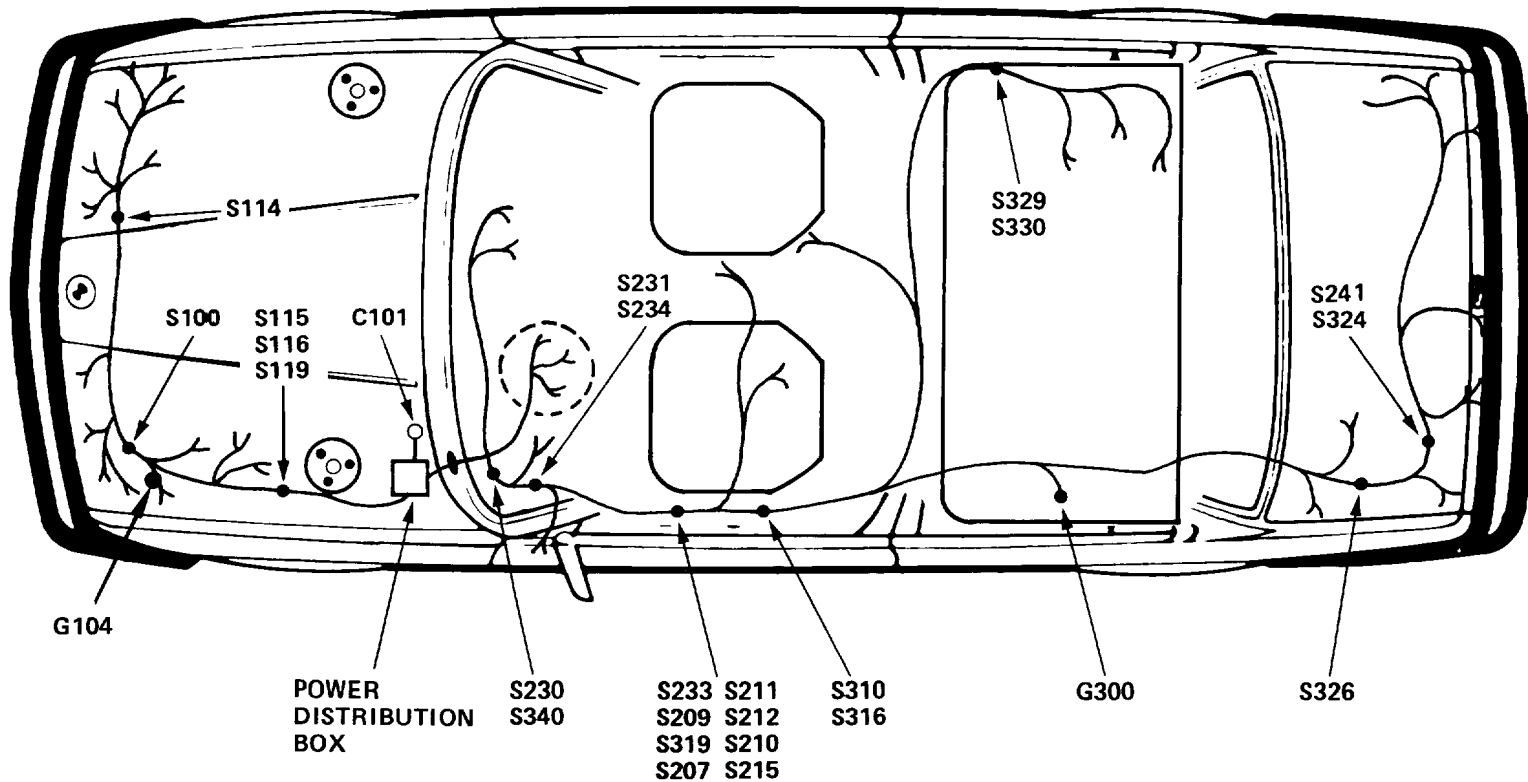
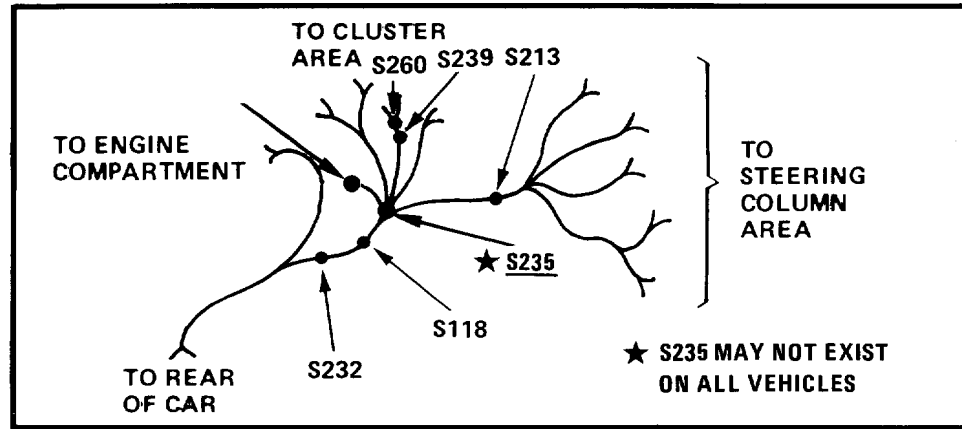

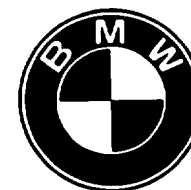

1991

BMW 325iX

Electrical

Troubleshooting

Manual

**BMW of North America, Inc.
Woodcliff Lake, New Jersey**

**1991
BMW 325iX
Electrical
Troubleshooting
Manual**

CONTENTS

Index	2
How To Use This Manual	3
Wire Size Conversion Chart . . .	3
Symbols	4
Systematic Troubleshooting . .	6
Connector Views	8500-0
Power Distribution Box	0670-0
Fuse Data	0670-1
Component Location Chart . . .	9000-0
Component Location Views . .	7000-0
Splice Location Views	8000-0

GROUND DISTRIBUTION: G200 (PARTIAL)

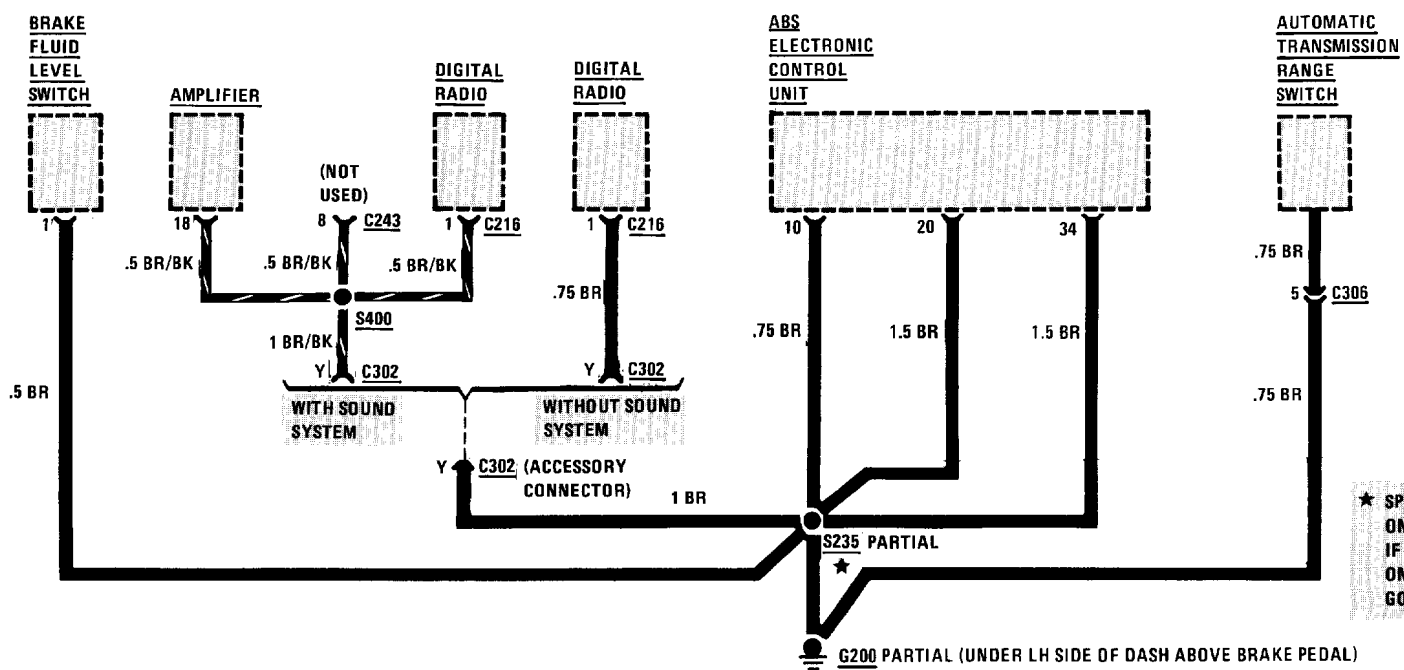
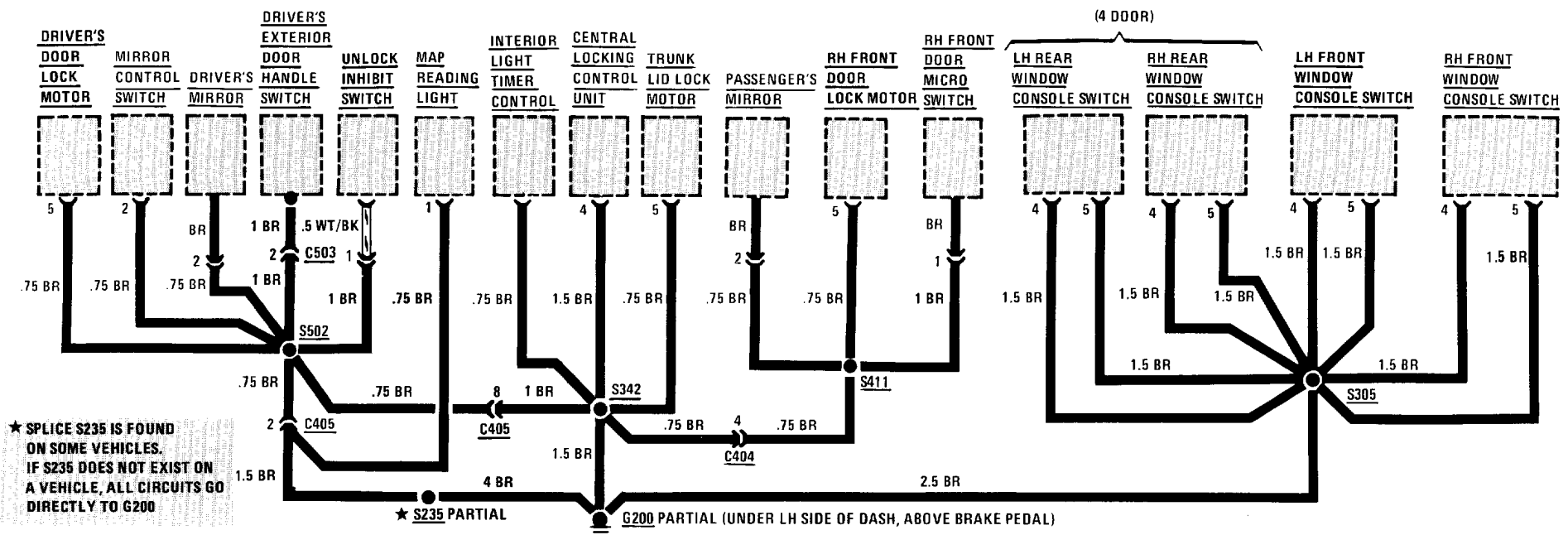

GROUND DISTRIBUTION: G200 (PARTIAL) AND G202

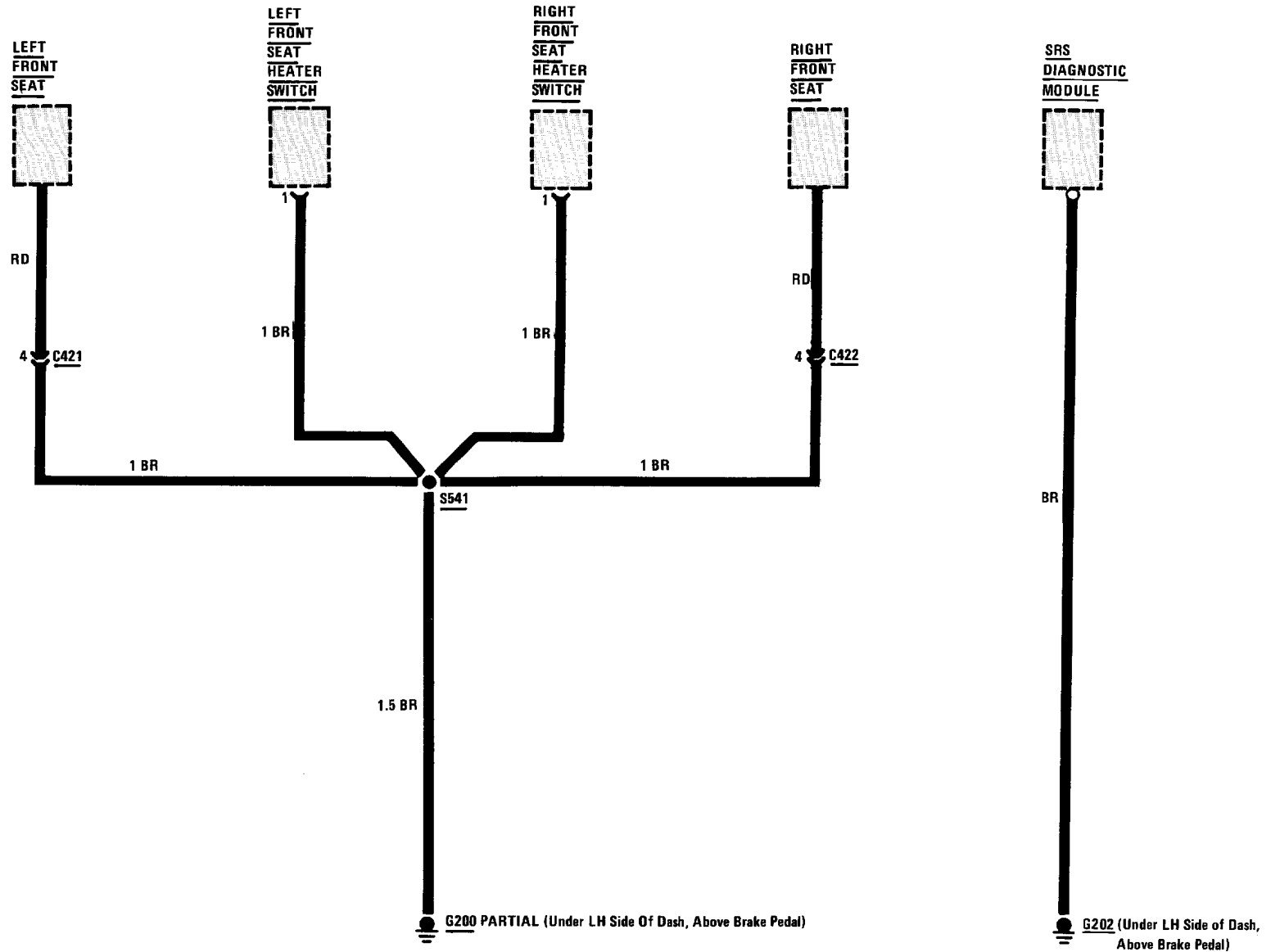

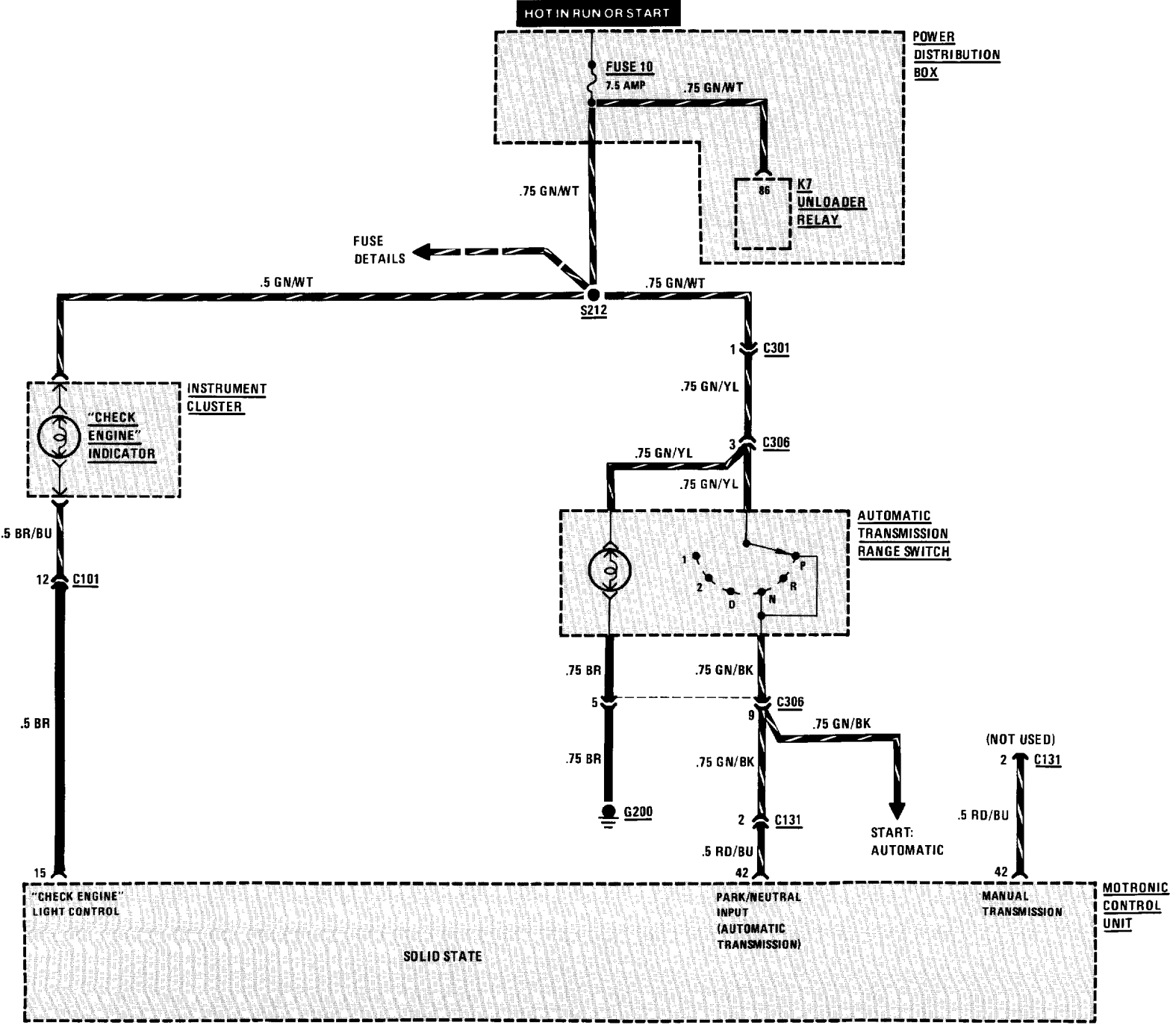

3234-0 SUPPLEMENTAL RESTRAINT SYSTEM (SRS)

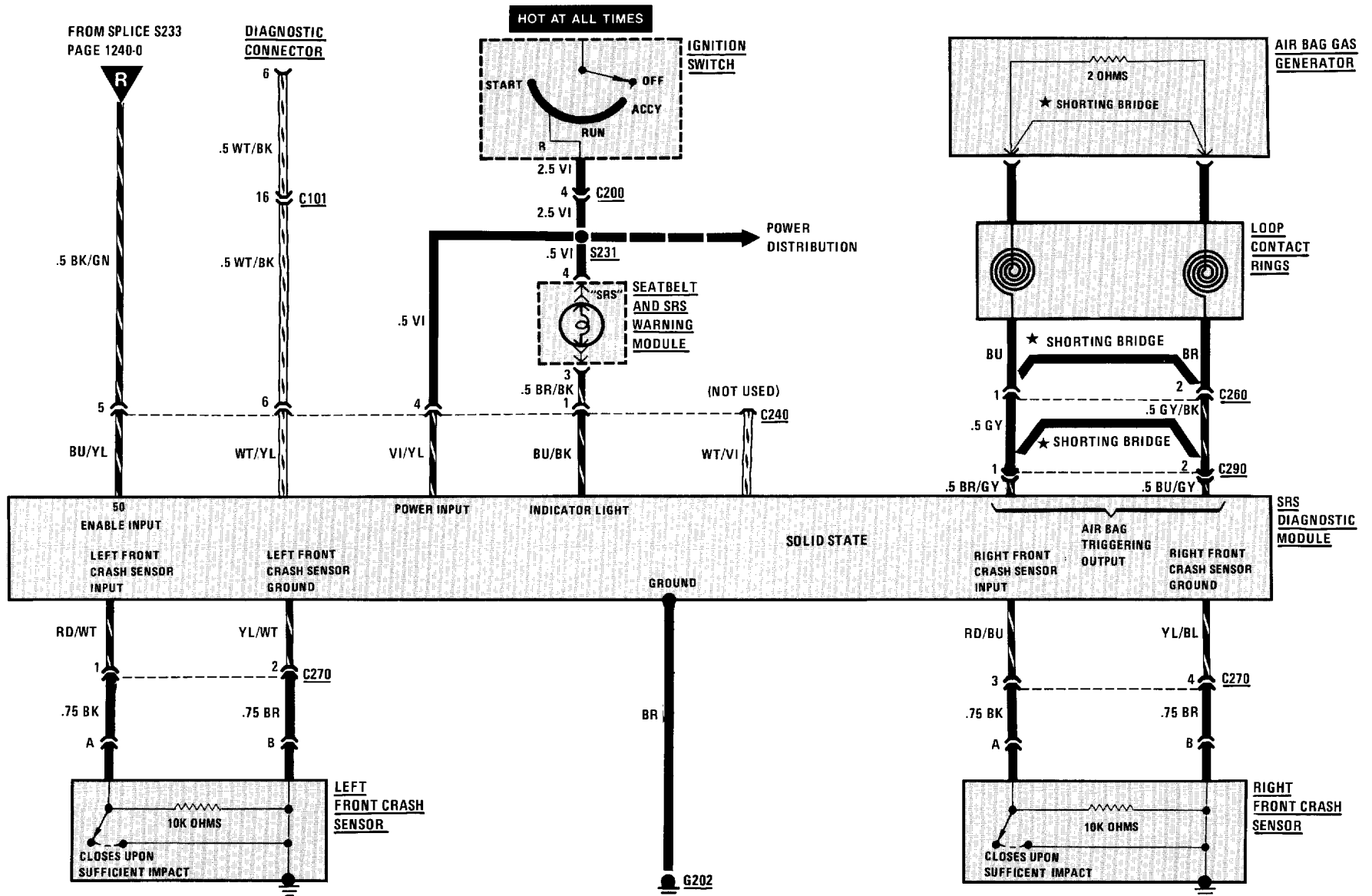

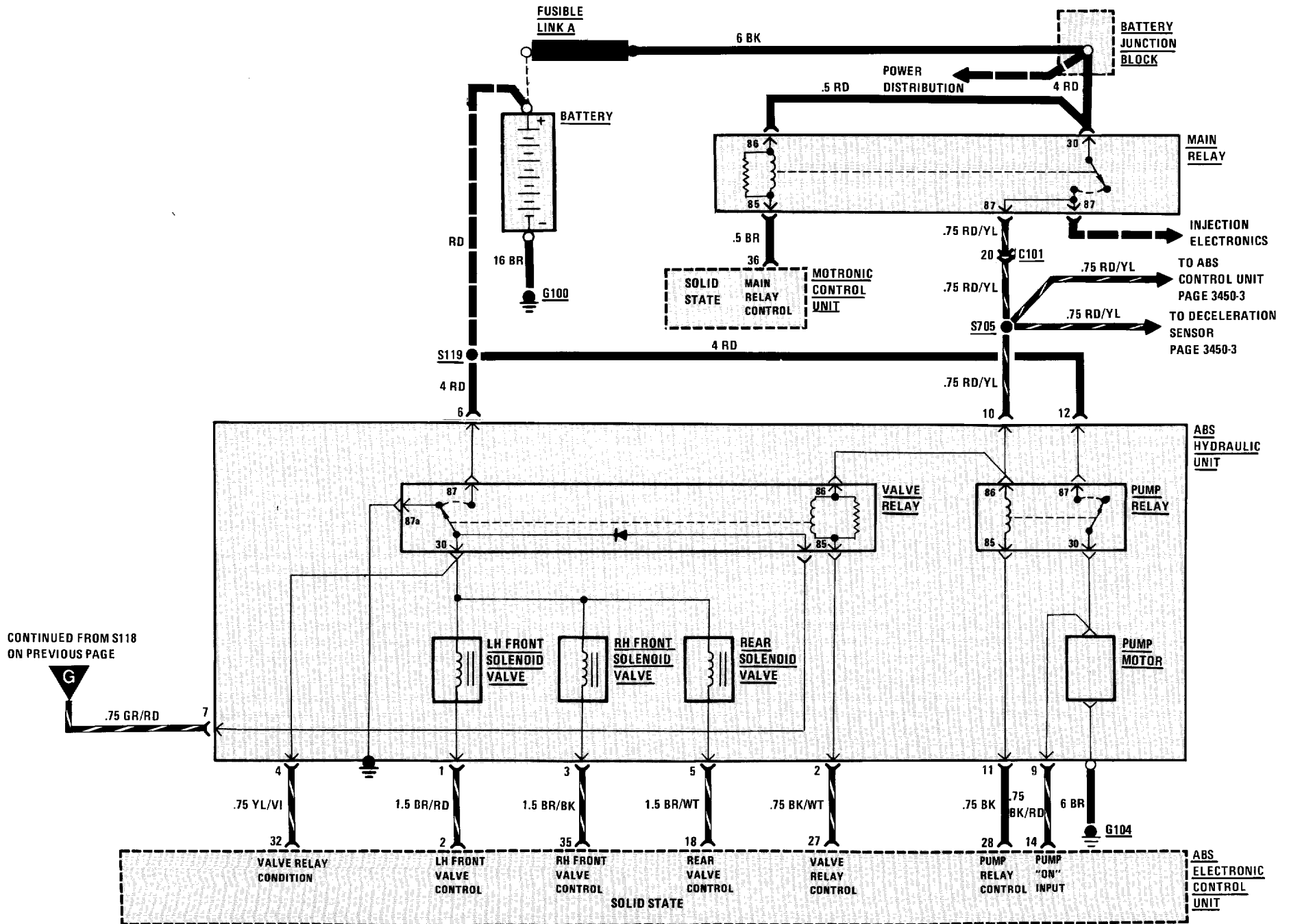

CONTINUED FROM S118
ON PREVIOUS PAGE



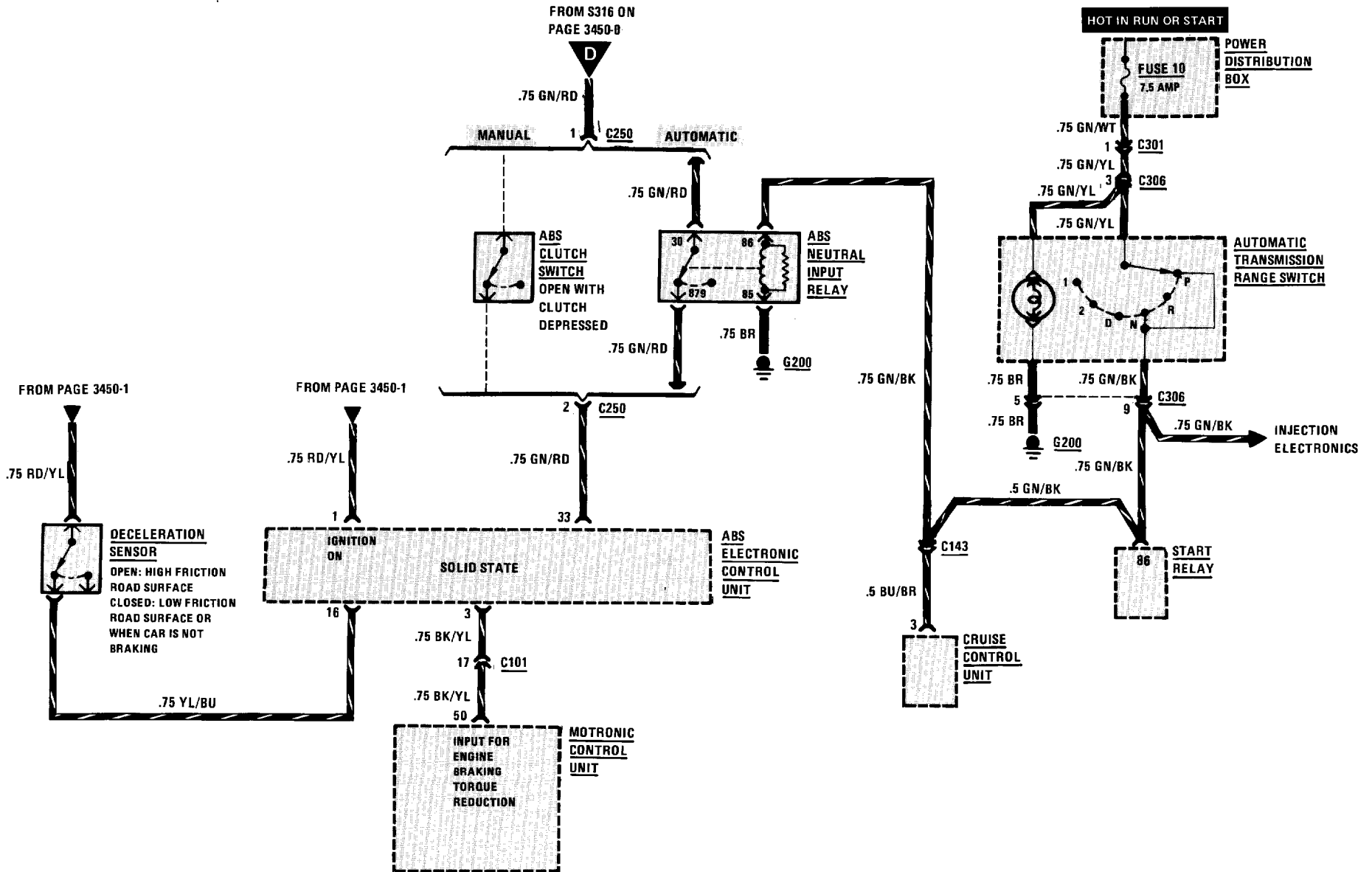

6160-0 WIPER/WASHER

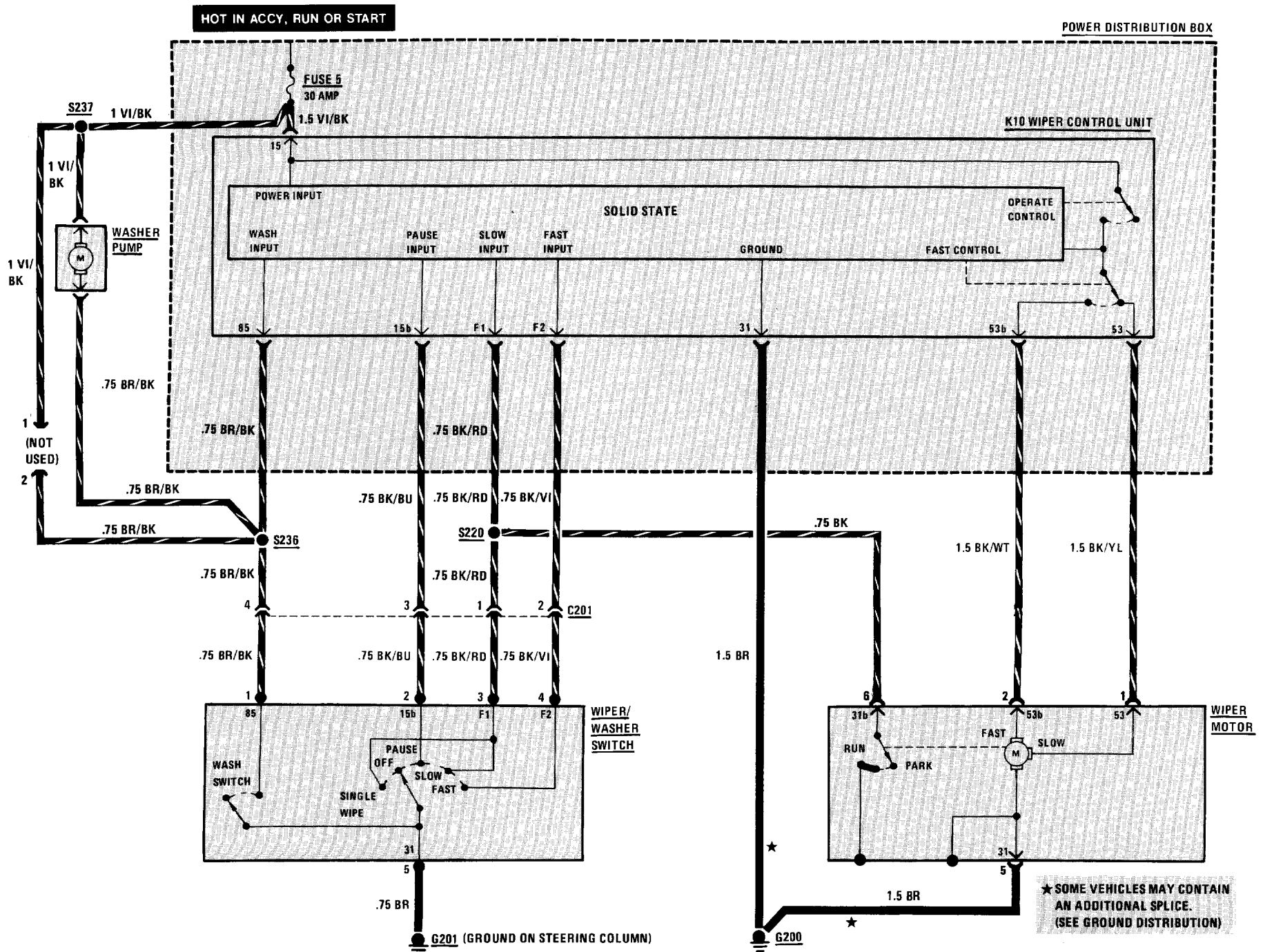

6300-0 LIGHT SWITCH DETAILS

HOT AT ALL TIMES

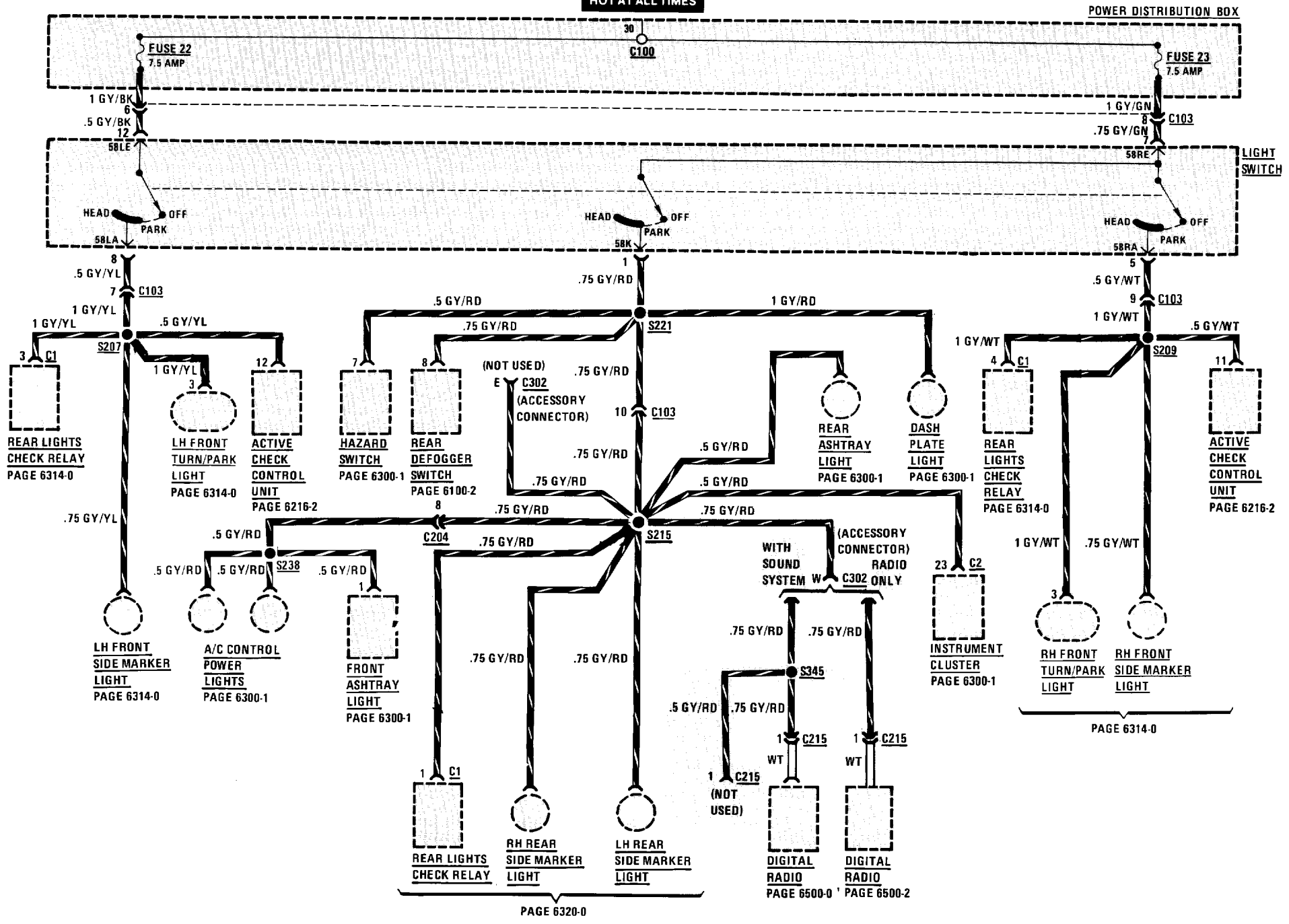

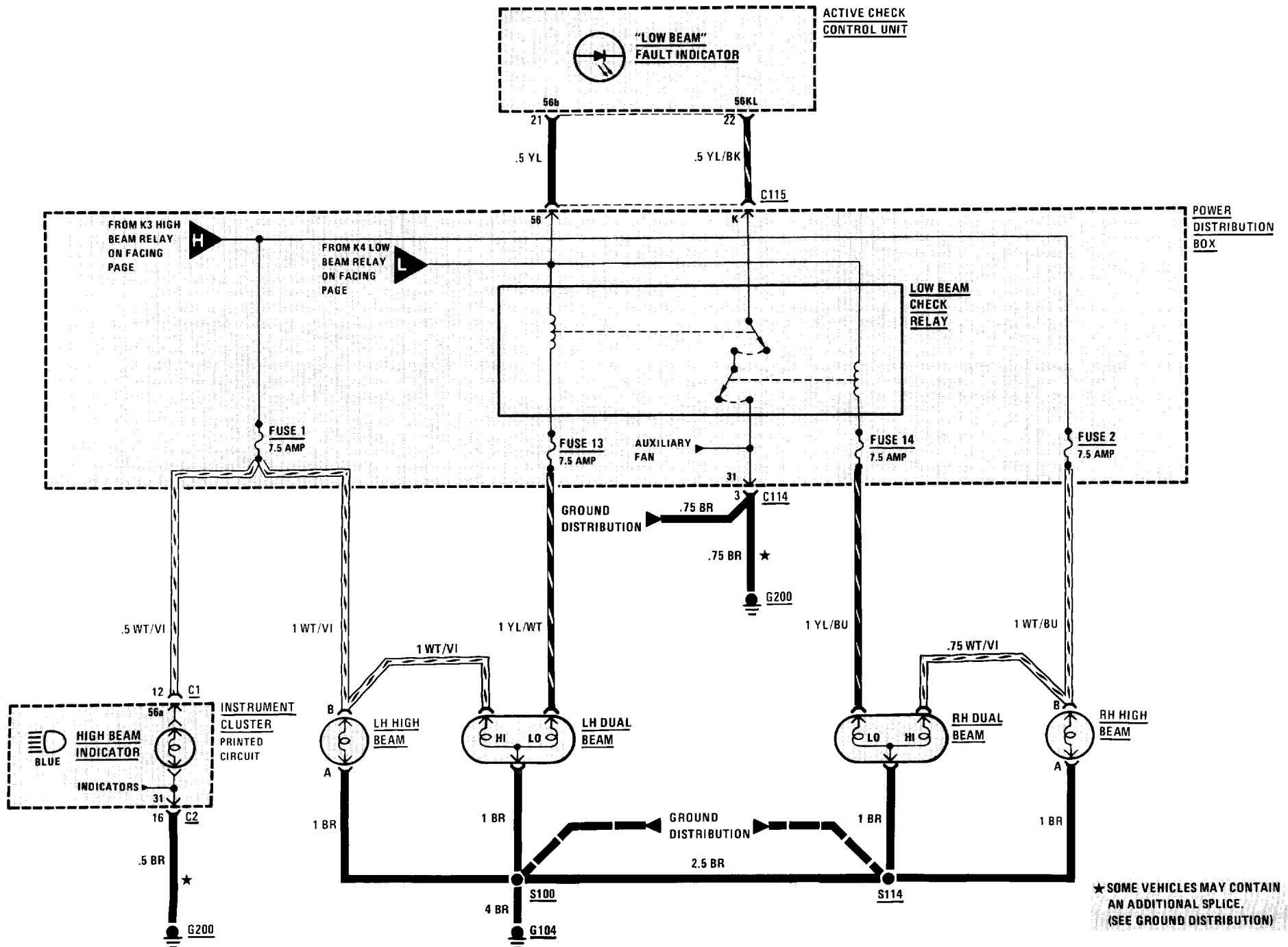

6314-0 PARK/TAIL/FRONT MARKER LIGHTS

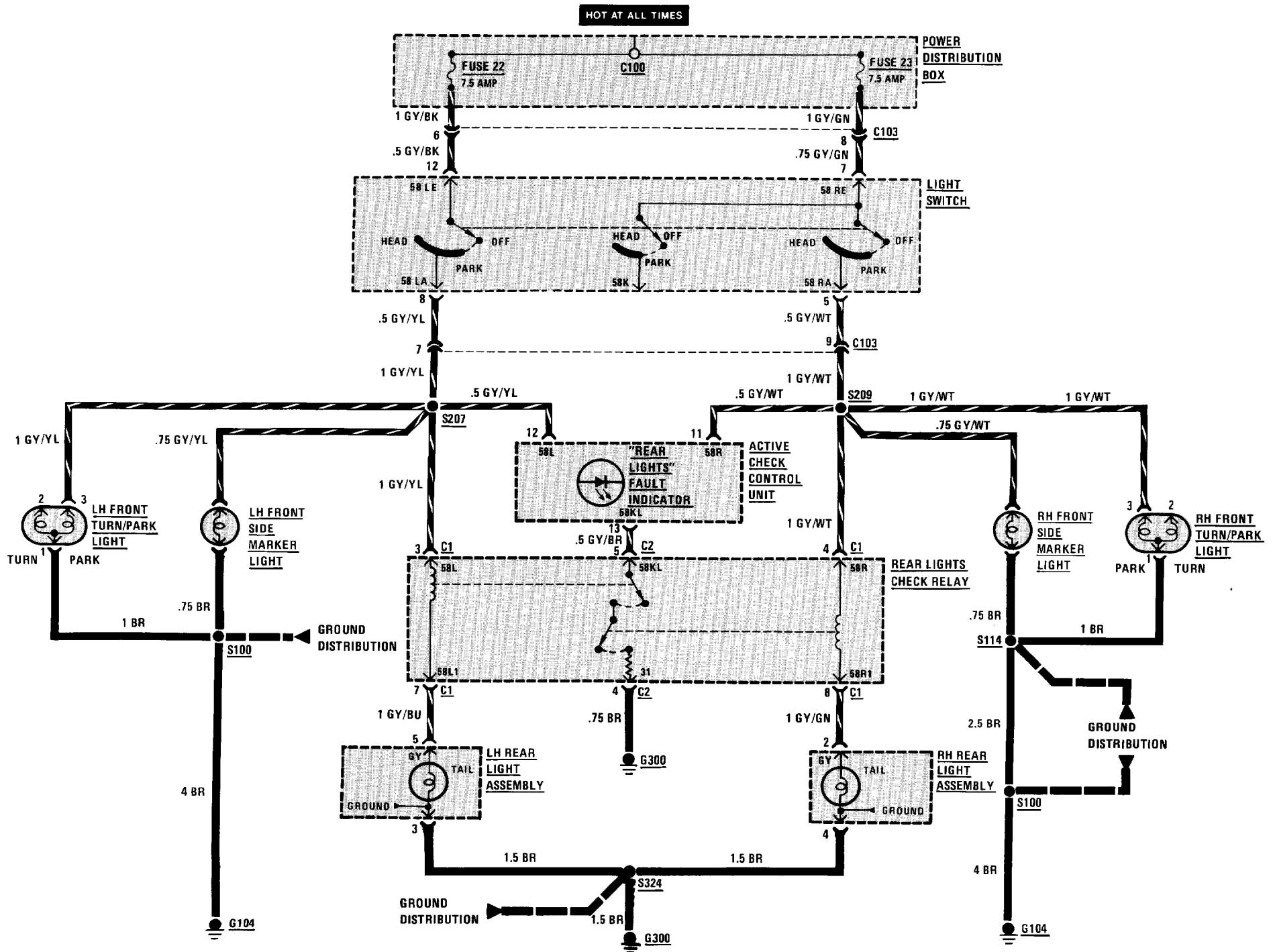

6320-0 REAR MARKER/LICENSE/TRUNK LIGHTS

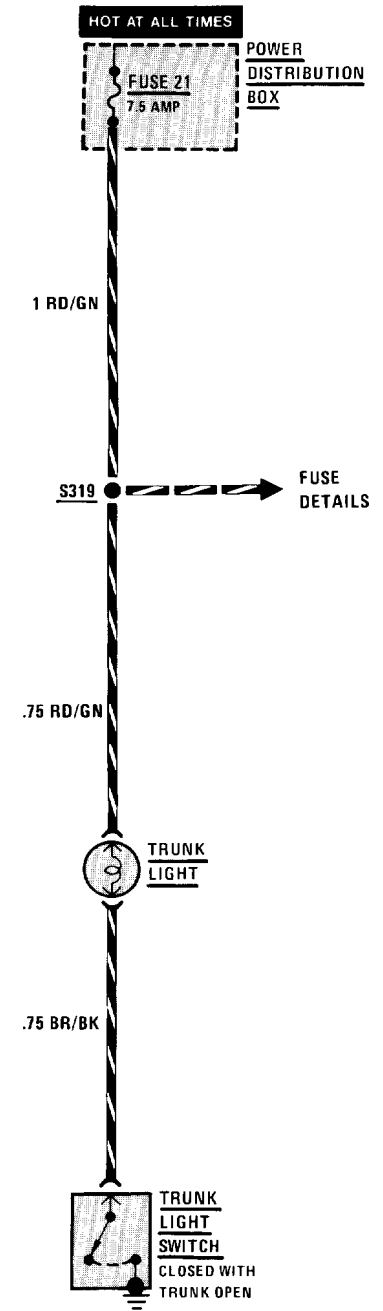
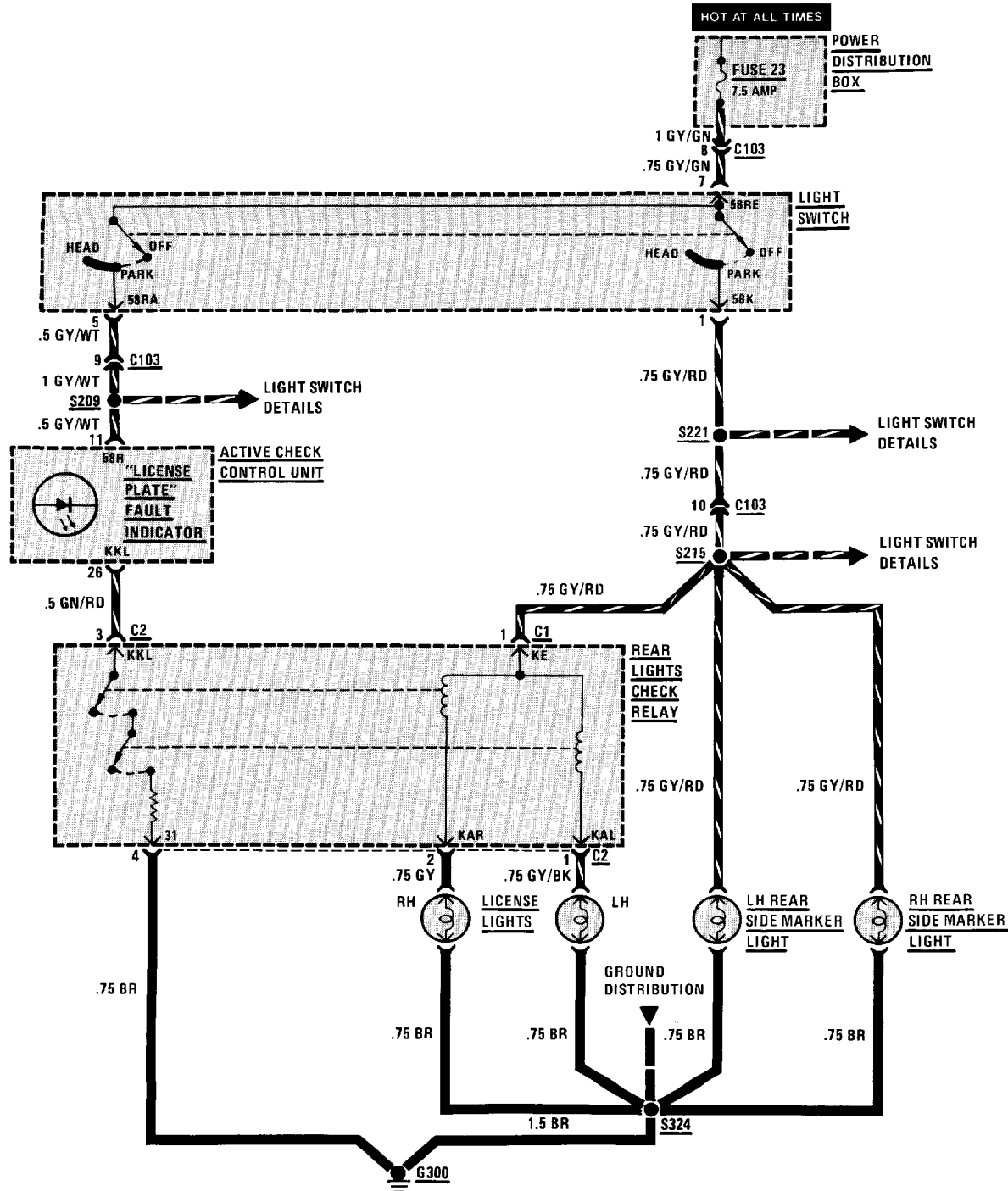

8000-0 SPLICE LOCATION VIEWS

INDEX

This index lists all the splices in the vehicle, the harness location of each splice, and the page on which each splice appears. The drawings after the index show how the harnesses are routed through the vehicle and the location of the splices on the harnesses.

SPLICE	HARNESS	PAGE NUMBER	SPLICE	HARNESS	PAGE NUMBER
S100	MAIN	8000-2	S221	INSTRUMENT	
S101	ENGINE	8000-2		PANEL	8000-5
S104	ENGINE	8000-3	S223	CRUISE	NOT
S105	ENGINE	8000-3		CONTROL	SHOWN
S106	ENGINE	8000-3	S224	MULTI-	
S107	ENGINE	8000-3		FUNCTION	NOT
S109	ENGINE	8000-3		CLOCK	SHOWN
S111	ENGINE	8000-3	S225	MULTI-	
S112	ENGINE	8000-3		FUNCTION	NOT
S113	ENGINE	8000-3		CLOCK	SHOWN
S114	MAIN	8000-2	S226	A/C	NOT
S115	MAIN	8000-2			SHOWN
S116	MAIN	8000-2	S228	CRUISE	NOT
S118	MAIN	8000-2		CONTROL	SHOWN
S119	MAIN	8000-2	S229	AIR	NOT
S120	ENGINE	8000-3		CONDITIONING	SHOWN
S207	MAIN	8000-2	S230	MAIN	8000-2
S209	MAIN	8000-2	S231	MAIN	8000-2
S210	MAIN	8000-2	S232	MAIN	8000-2
S211	MAIN	8000-2	S233	MAIN	8000-2
S212	MAIN	8000-2	S234	MAIN	8000-2
S213	MAIN	8000-2	S235	MAIN	8000-2
S215	MAIN	8000-2	S236	MAIN	8000-2
S219	INSTRUMENT		S237	MAIN	8000-2
	PANEL	8000-5	S238	MAIN	NOT
S220	MAIN	8000-2			SHOWN

INDEX

SPLICE	HARNESS	PAGE NUMBER	SPLICE	HARNESS	PAGE NUMBER
S239	MAIN	8000-2	S340	MAIN	8000-2
S240	AIR	NOT	S341	MAIN	8000-2
	CONDITIONING	SHOWN	S342	DOOR	8000-4
S241	MAIN	8000-2	S345	RADIO	NOT
S250	AIR	NOT			SHOWN
	CONDITIONING	SHOWN	S400	RADIO	NOT
S251	AIR	NOT			SHOWN
	CONDITIONING	SHOWN	S402	DOOR	8000-4
S252	AIR	NOT	S403	RADIO	NOT
	CONDITIONING	SHOWN			SHOWN
S260	MAIN	8000-2	S404	RADIO	NOT
S300	DOOR	8000-4			SHOWN
S301	DOOR	8000-4	S411	DOOR	8000-4
S302	DOOR	8000-4	S420	RADIO	NOT
S303	DOOR	8000-4			SHOWN
S304	DOOR	8000-4	S501	DOOR	8000-4
S305	DOOR	8000-4	S502	DOOR	8000-4
S306	INSTRUMENT		S503	DOOR	8000-4
	PANEL	8000-5	S504	DOOR	8000-4
S307	INSTRUMENT		S540	HEATED SEATS	NOT
	PANEL	8000-5			SHOWN
S309	DOOR	8000-4	S541	HEATED SEATS	NOT
S310	MAIN	8000-2			SHOWN
S313	RADIO	NOT	S542	HEATED SEATS	NOT
		SHOWN			SHOWN
S316	MAIN	8000-2	S543	HEATED SEATS	NOT
S319	MAIN	8000-2			SHOWN
S322	DOOR	8000-4	S700	ENGINE	8000-3
S323	DOOR	8000-4	S701	ENGINE	8000-3
S324	MAIN	8000-2	S702	ENGINE	8000-3
S329	MAIN	8000-2	S704	ENGINE	8000-3
S330	MAIN	8000-2	S705	MAIN	8000-2
S332	DOOR	8000-4			
S333	DOOR	8000-4			

8000-2 SPLICE LOCATION VIEWS

MAIN HARNESS SPLICE LOCATIONS

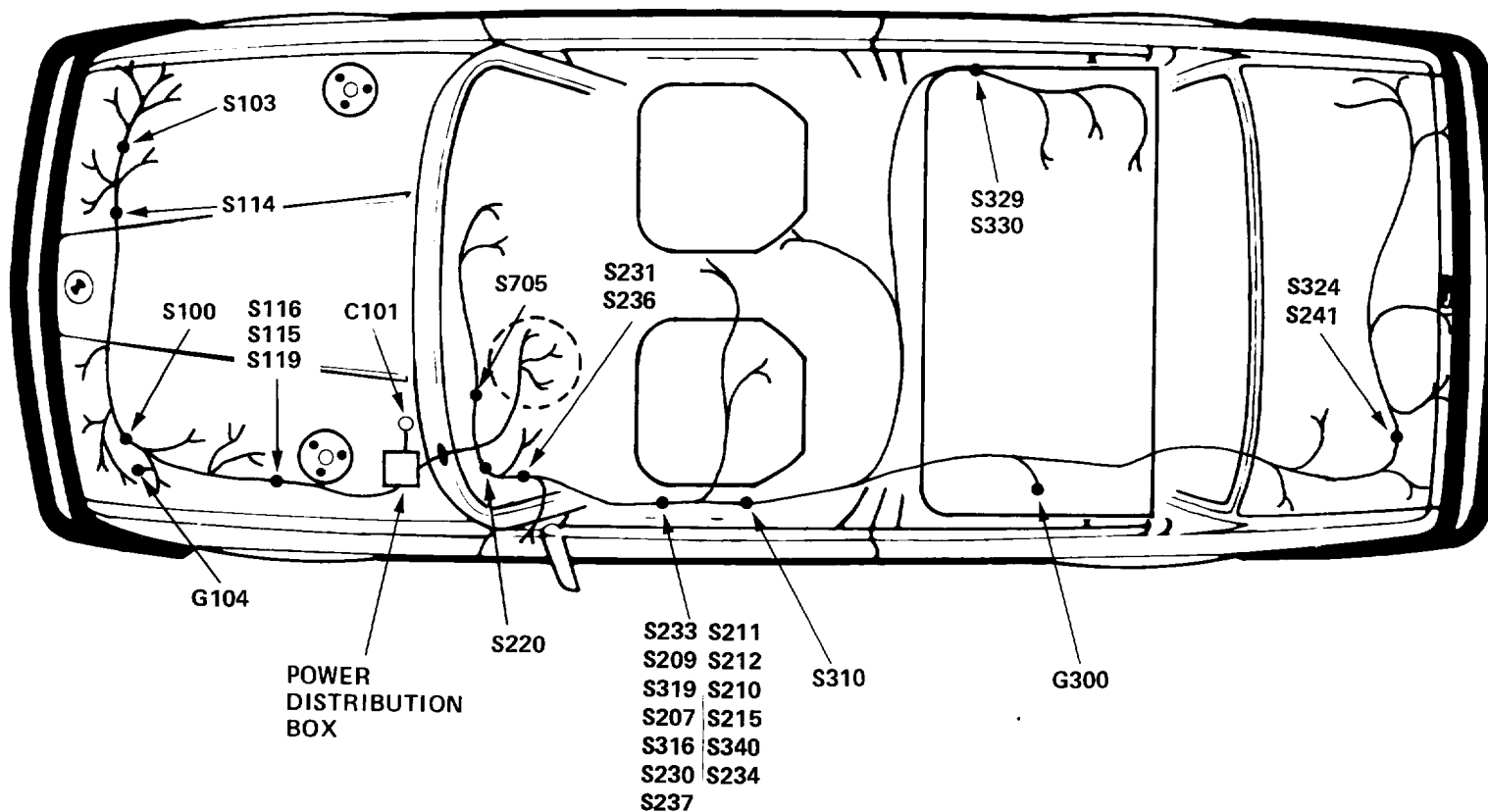
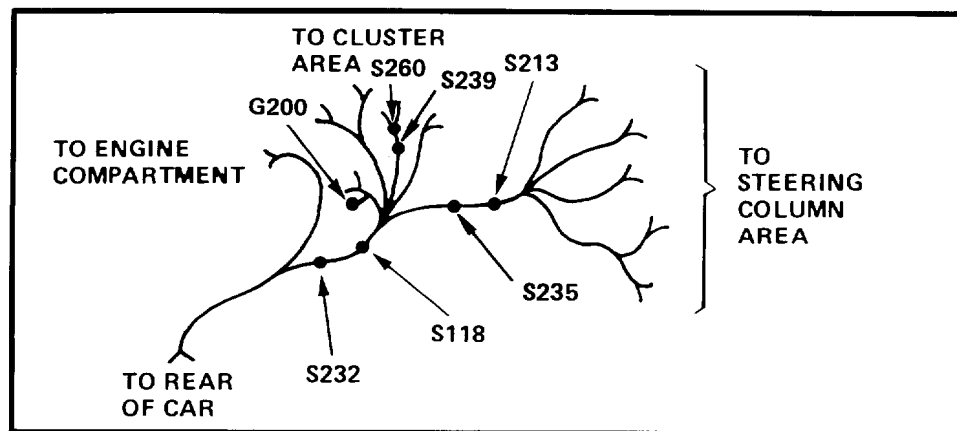



1991

BMW M3

Electrical

Troubleshooting

Manual

BMW of North America, Inc.
Woodcliff Lake, New Jersey

**1991
BMW M3
Electrical
Troubleshooting
Manual**

CONTENTS

Index	2
How To Use This Manual	3
Wire Size Conversion Chart . . .	3
Symbols	4
Systematic Troubleshooting . .	6
Connector Views	8500-0
Power Distribution Box	0670-0
Fuse Data	0670-1
Component Location Chart . . .	9000-0
Component Location Views . .	7000-0
Splice Location Views	8000-0

3234-0 SUPPLEMENTAL RESTRAINT SYSTEM (SRS)

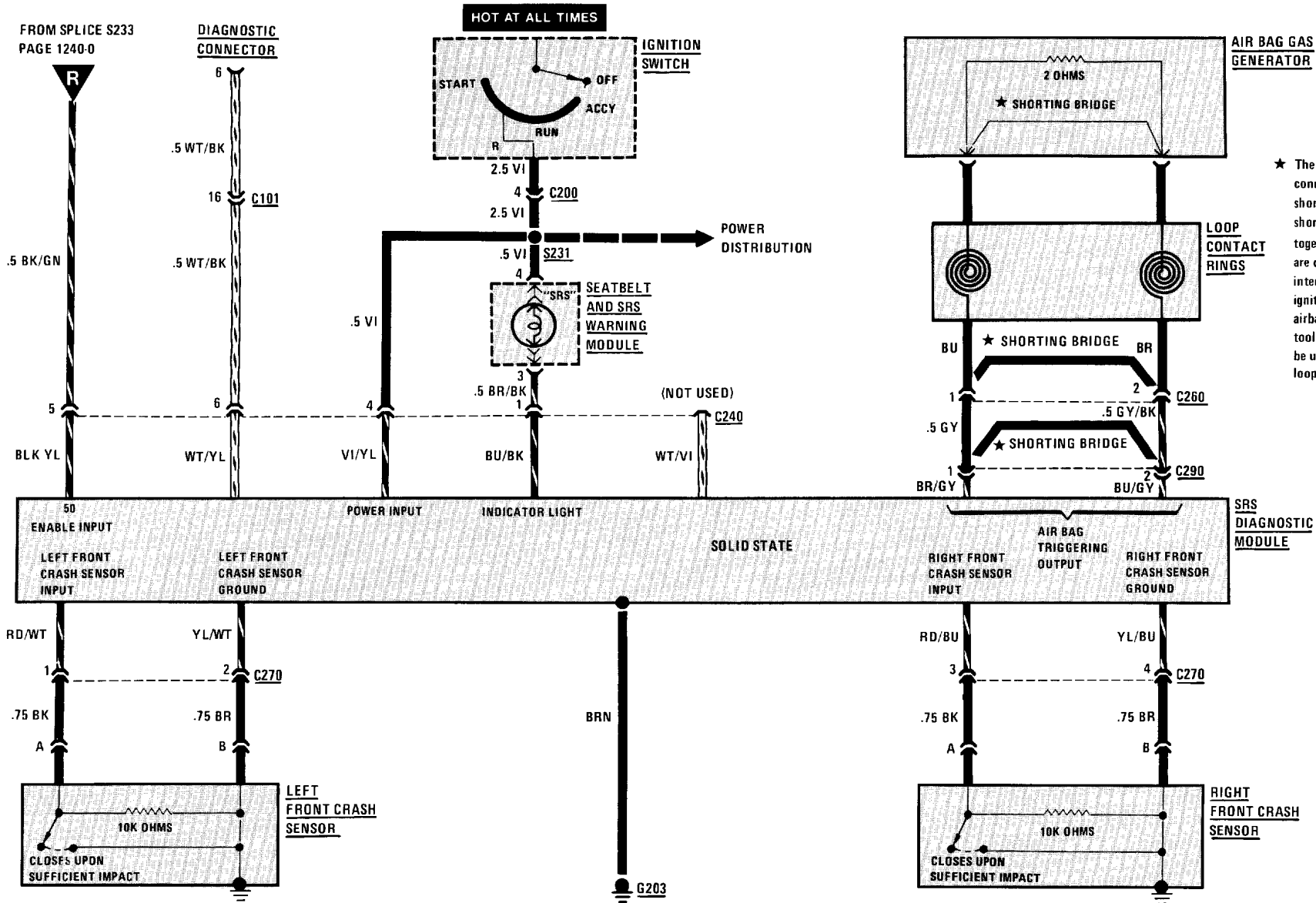

★ The driver's airbag generator connectors are fitted with shorting bridges. The bridges short the generator leads together when the connectors are demated to prevent unintentional triggering of the igniter, when working on the airbag system. Only special tool 62 1260 (test lead) may be used to check the wire loop and igniter resistance.

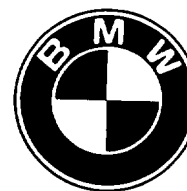

1991

BMW 325i Convertible

Electrical

Troubleshooting

Manual

BMW of North America, Inc.
Woodcliff Lake, New Jersey

**1991
BMW 325i Convertible
Electrical
Troubleshooting
Manual**

CONTENTS

Index	2
How To Use This Manual . .	3
Wire Size Conversion Chart .	3
Symbols	4
Systematic Troubleshooting	6
Connector Views.	8500-0
Power Distribution Box	0670-0
Fuse Data	0670-1
Component Location Chart .	9000-0
Component Location Views	7000-0
Splice Location Views	8000-0

Index — Alphabetical Listing of Electrical Circuits

	PAGE		PAGE		PAGE
Active Check Control	6216-0	— G200	0670-13	Cigar Lighter	6300-1
A/C Air Delivery Control	6421-0		0670-14	— Dash	6300-1
A/C Blower Controls	6413-0		0670-15	— Fog	6312-0
A/C Compressor Controls	6452-0		0670-16	— Front Side Marker	6314-0
A/C Temperature Control	6411-0	— G201	0670-14	— Front Turn/Park	6314-0
Antilock Braking System (ABS)	3450-0	— G202	0670-17	— Glove Box	6100-1
Auto-Charging Flashlight	6100-1	— G300	0670-17	— Hazard Switch	6313-0
Auxiliary Fan	6454-0	Heated Seats	5200-0	— Headlights	6312-0
Auxiliary Fuse	0670-2	Horns	6100-0	— Instrument Cluster	6300-1
Brake Warning System	3435-0	Ignition Key Warning	6131-0	— Interior	6330-0
Central Locking	5126-0	Indicators		— License	6320-0
Charge System	1230-0	— Active Check Control Alarm	6216-2	— Map Reading Light	6100-1
Cigar Lighter	6100-1	— “Brake Lights” Fault	6216-1	— Park	6314-0
Component Location Chart	9000-0	— “Brake Lining” Wear	3435-0	— Rear Side Marker	6320-0
Component Location Views	7000-0	— “Brake” Warning	3435-0	— Stop	6325-0
Connector Views	8500-0	— Charge	1230-0	— Tail	6314-0
Cruise Control	6571-0	— “Coolant” Level Fault	6216-2	— Trunk	6320-0
Electro-Mechanical Convertible		— “Engine Oil” Fault	6216-2	— Turn/Hazard	6313-0
Top	5400-0	— Fasten Seatbelts	6216-2	Light Switch Details	6300-0
Fuel Economy Gauge	6210-3	— Fog Lights	6312-0	On-Board Computer	6581-0
Fuel Gauge	6210-1	— High Beam	6312-1	Power Antenna	6500-0
Fuse Data Chart	0670-1	— Inspection	6210-2	Power Distribution	0670-0
Fuse Details		— LH Turn	6313-1	Power Distribution Box	0670-0
— Fuse 4	0670-6	— “License Plate” Fault	6216-1	Power Mirrors	5116-0
— Fuse 5	0670-6	— “Low Beam” Fault	6216-0	Power Windows	5133-0
— Fuse 6	0670-6	— Low Fuel Warning	6210-1	Radio	6500-0
— Fuse 8	0670-7	— Oil Pressure Warning	6210-1	Rear Defogger	6100-2
— Fuse 9	0670-11	— Oil Service	6210-2	Seatbelt Warning	6131-0
— Fuse 10	0670-8	— “Park Brake”	3435-0	Service Interval Indicator	6210-2
— Fuse 12	0670-7	— “Rear Lights” Fault	6216-1	Speedometer	6210-0
— Fuse 19	0670-7	— RH Turn	6313-1	Splice Location Views Index	8000-0
— Fuse 20	0670-9	— “Washer Fluid” Fault	6216-2	Start	
— Fuse 21	0670-10	Injection Electronics	1360-0	— Automatic	1240-0
— Fuse 27	0670-11	Instrument Cluster	6210-0	— Manual	1240-1
Gauges	6210-1	Lights		Tachometer	6210-3
Ground Distribution		— A/C Control Power	6300-1	Temperature Gauge	6210-1
— G103	0670-12	— Ashtray, Rear	6300-1	Warnings	
— G104	0670-13	— Back Up	6322-0	— Ignition Key/Seatbelt	6131-0
				Wiper/Washer	6160-0

FUSE DATA CHART

FUSE NO.	SIZE	CIRCUIT NAME
1	7.5A	Headlights (also fuses 2, 13, 14); High Beam Indicator.
2	7.5A	Headlights (also fuses 1, 13, 14).
3	15A	Auxiliary Fan (also fuses 18, 19, 20).
4	15A	Lights: Turn/Hazard Warning (also fuse 24); Active Check Control (also fuses 6, 10, 21, 22, 23). Glove Box Light; Electro-Mechanical Convertible Top (also fuses 21, 25).
5	30A	Wiper/Washer.
6	7.5A	Stop Lights/Cruise Control Active Check Control (also fuses 4, 10, 21, 22, 23); Antilock Braking System; Cruise Control (also fuse 10); Map Reading Light.
7	15A	Horn.
8	30A	Rear Defogger (also fuse 23).
9	15A	Injection Electronics (also fuses 10, 11, 21).
10	7.5A	Ignition Key Warning/Seatbelt Warning (also Fuse 21); Service Interval Indicator (also fuse 21); Tachometer/Fuel Economy Gauges (also fuse 21); Gauges/Indicators; Brake Warning System; Back Up Lights; On-Board Computer (also fuses 12, 21, 27); Start; Injection Electronics (also fuses 9, 11, 21); Active Check Control (also fuses 4, 6, 21, 22, 23); Cruise Control (also fuse 6).
11	7.5A	Injection Electronics (also fuses 9, 10, 21).
12	7.5A	Radio (also fuses 21, 27, 28); Speedometer/Indicators; On-Board Computer (also fuses 10, 21, 27).
13	7.5A	Headlights (also fuses 1, 2, 14).
14	7.5A	Headlights (also fuses 1, 2, 13).
15		Not Used.
16	15A	Heated Seats.
17	30A	Power Windows.
18	30A	Auxiliary Fan (also fuses 3, 19, 20).
19	7.5A	Auxiliary Fan (also fuses 3, 18, 20); Interior Lights (also fuses 21, 27); Power Mirrors.

FUSE NO.	SIZE	CIRCUIT NAME
20	30A	Heater/Air Conditioning; Auxiliary Fan (also fuses 3, 18, 19).
21	7.5A	Auto-Charging Flashlight; Ignition Key Warning/Seatbelt Warning (also fuse 10); Injection Electronics (also fuses 9, 10, 11); Interior Lights (also fuses 19, 27); Radio/Antenna (also fuses 12, 27, 28); Trunk Light; Active Check Control (also fuses 4, 6, 10, 22, 23); Service Interval Indicator (also fuse 10); On-Board Computer (also fuses 10, 12, 23, 27); Tachometer/Fuel Economy Gauge (also fuse 10); Electro-Mechanical Convertible Top (also fuses 4, 25)
22	7.5A	Active Check Control (also fuses 4, 6, 10, 21, 23); Lights: Front Park/Tail (also fuse 23); Lights: Front Side Marker (also fuse 23).
23	7.5A	Lights: Dash; Lights: Front Park/Tail (also fuse 22); Lights: Front Side Marker (also fuse 22); Lights: Rear Marker/License; Active Check Control (also fuses 4, 6, 10, 21, & 22); Rear Defogger (also fuse 8).
24	15A	Lights: Turn/Hazard Warning (also fuse 4).
25	30A	Electro-Mechanical Covertible Top (also fuses 4, 21)
26		Not Used.
27	30A	Interior Lights (also fuses 19, 21); Central Locking; Radio/Antenna (also fuses 12, 21, 28); On-Board Computer (also fuses 10, 12, 21).
28	30A	Cigar Lighter; Radio/Antenna (also fuses 12, 21, 27).
29	7.5A	Fog Lights (also fuse 30), Fog Light Indicator.
30	7.5A	Fog Lights (also fuse 29).
POWER WINDOW CIRCUIT BREAKER		25A Power Windows

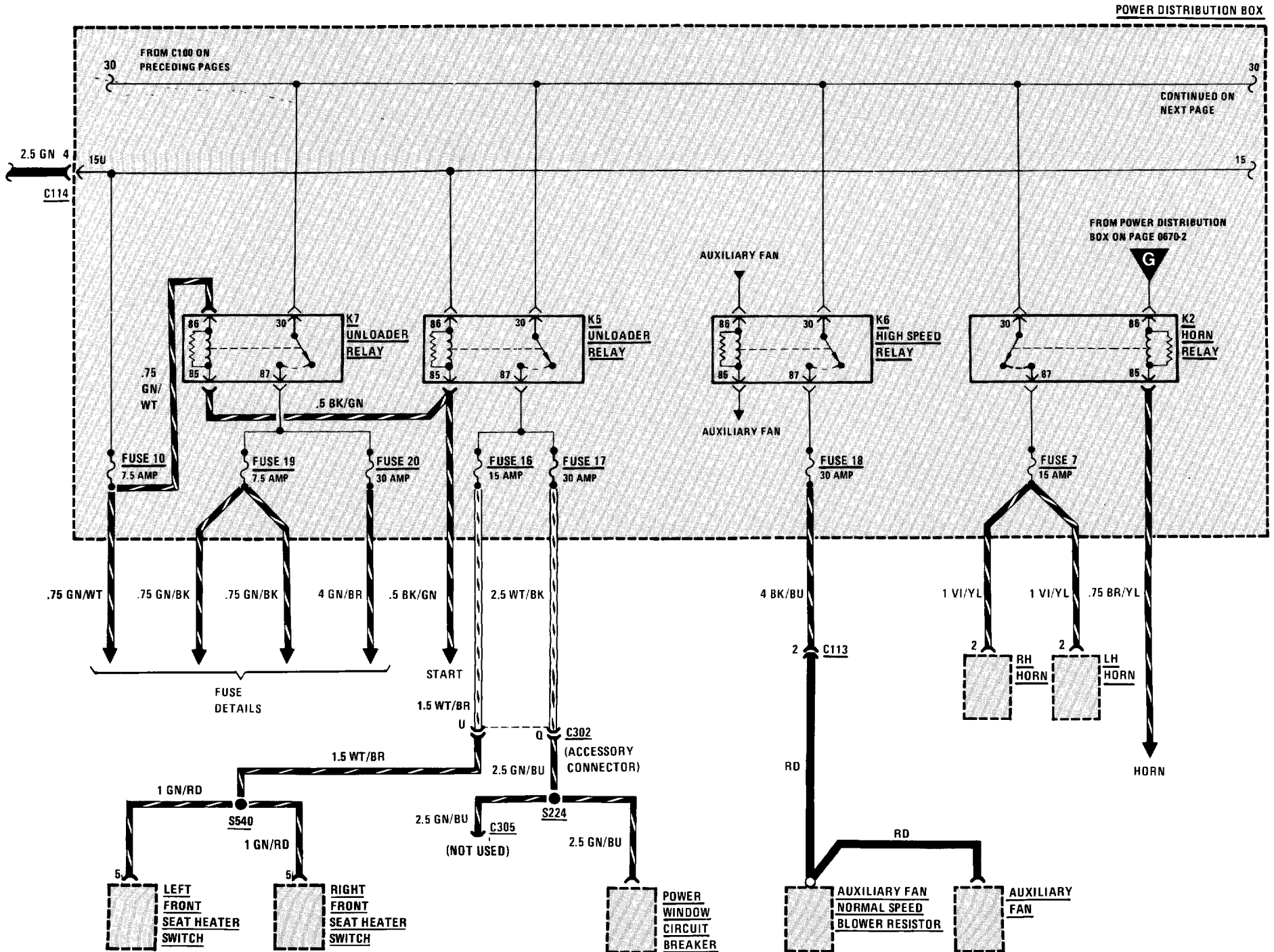

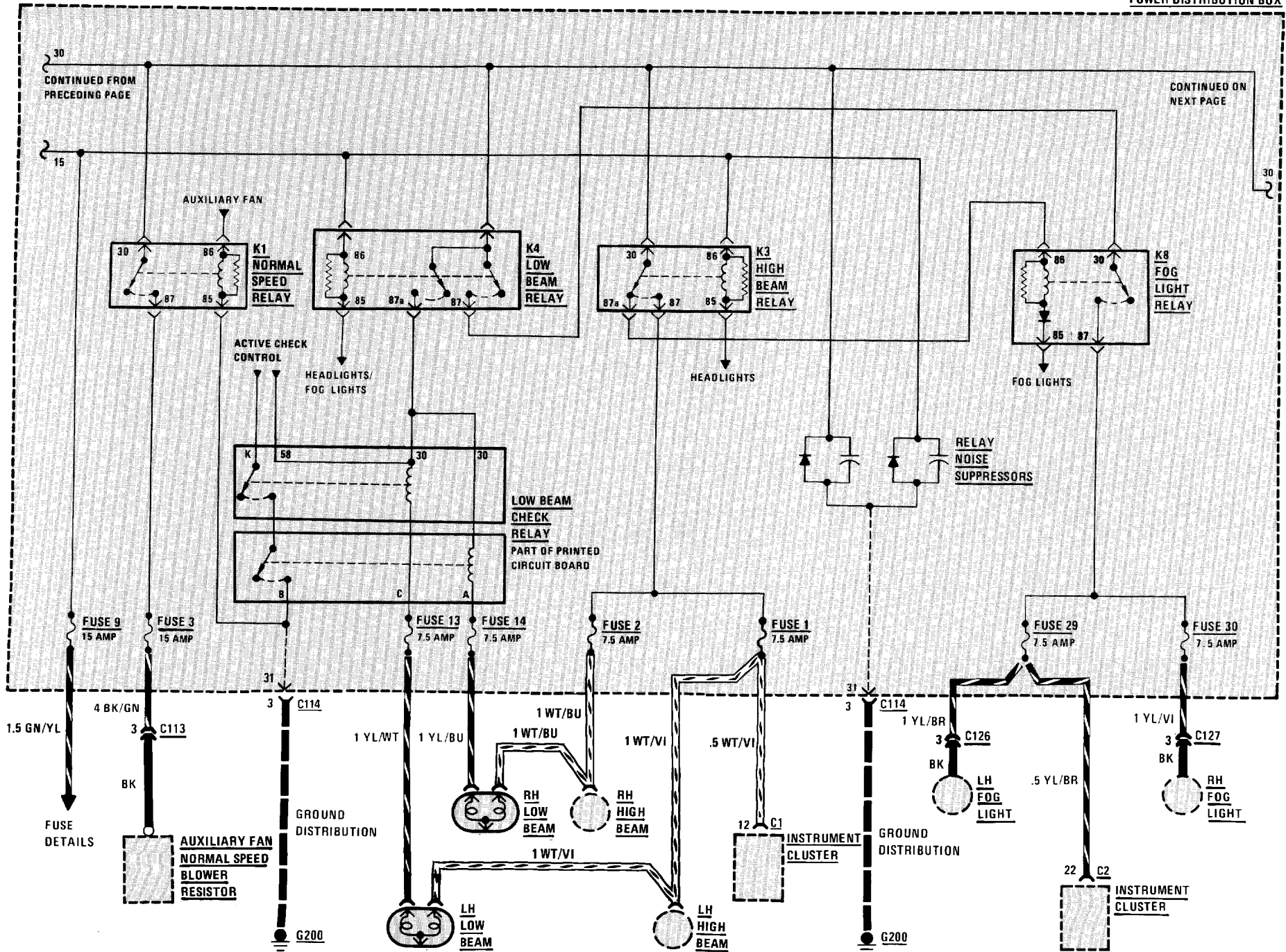

POWER DISTRIBUTION BOX

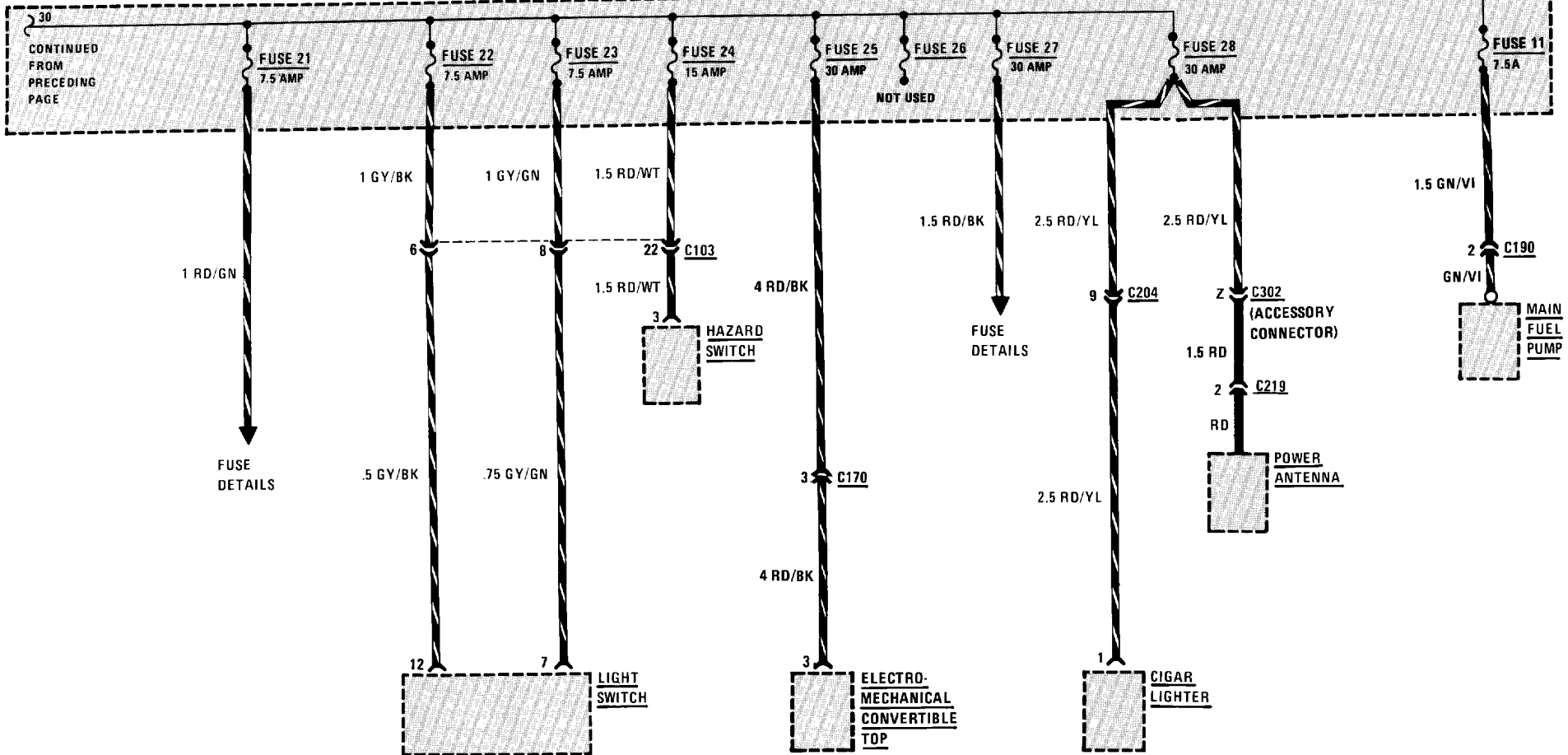

0670-6 POWER DISTRIBUTION

FUSE DETAILS: FUSES 4, 5, AND 6

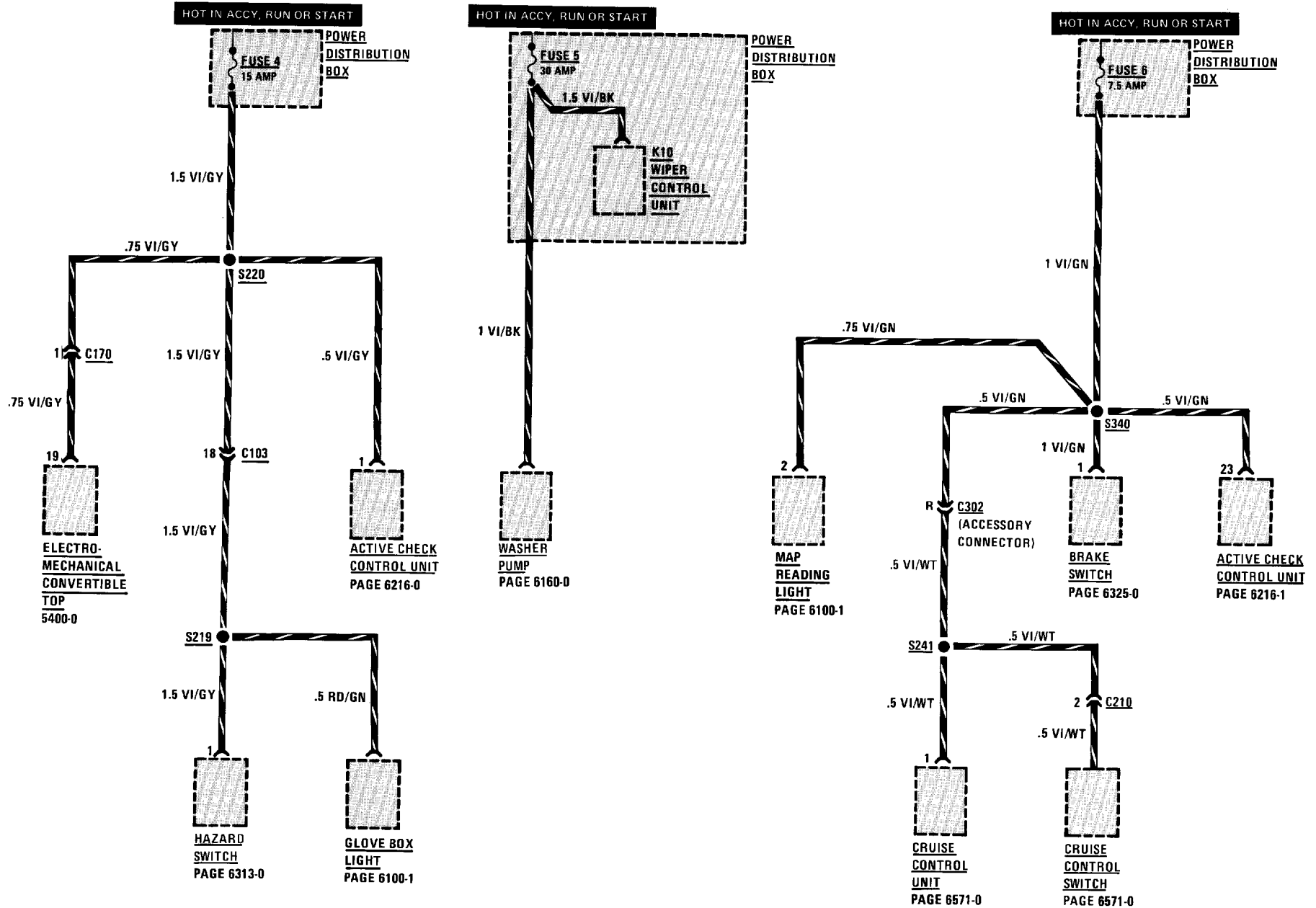

FUSE DETAILS: FUSE 21

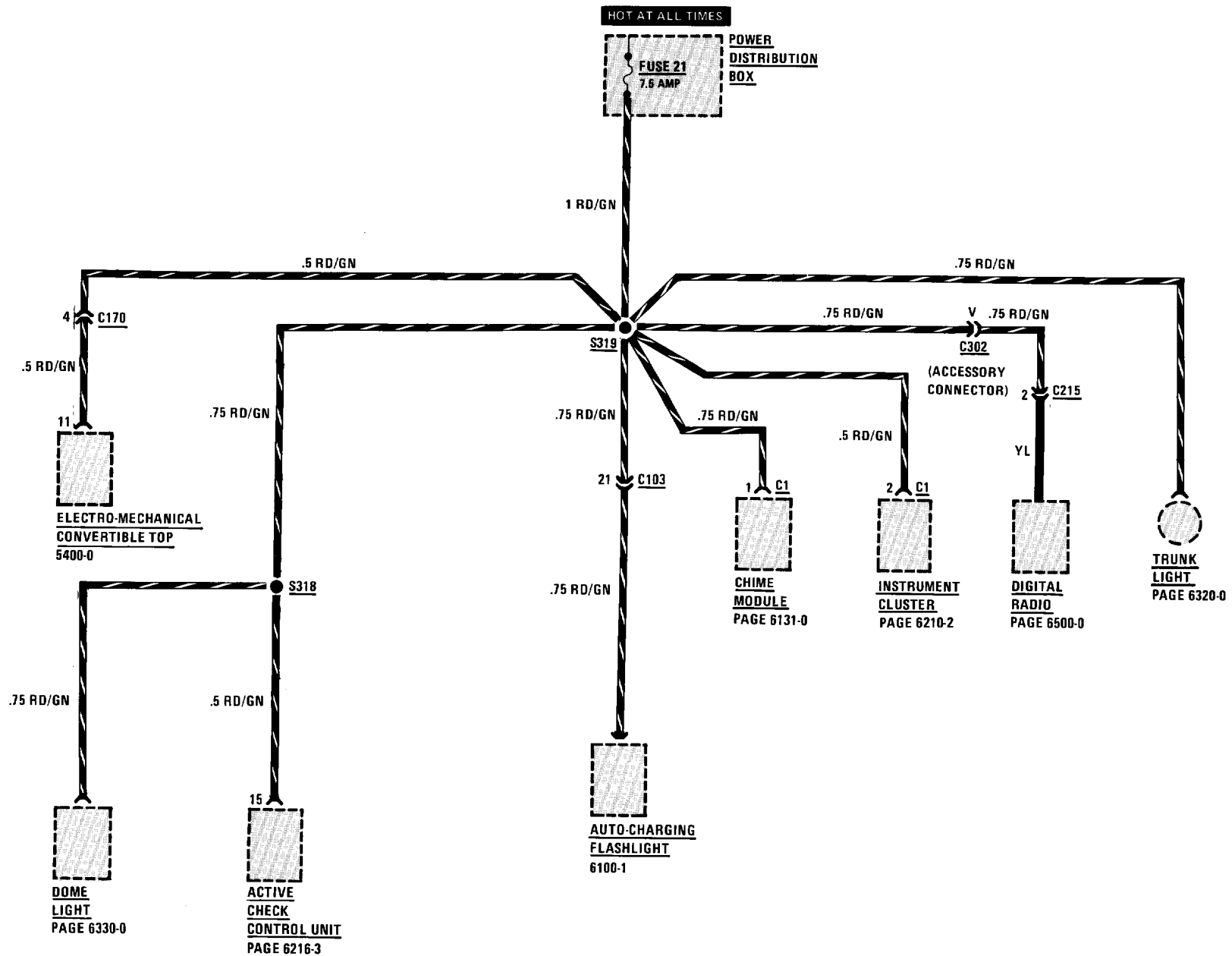

GROUND DISTRIBUTION: G104 AND G200 (PARTIAL)

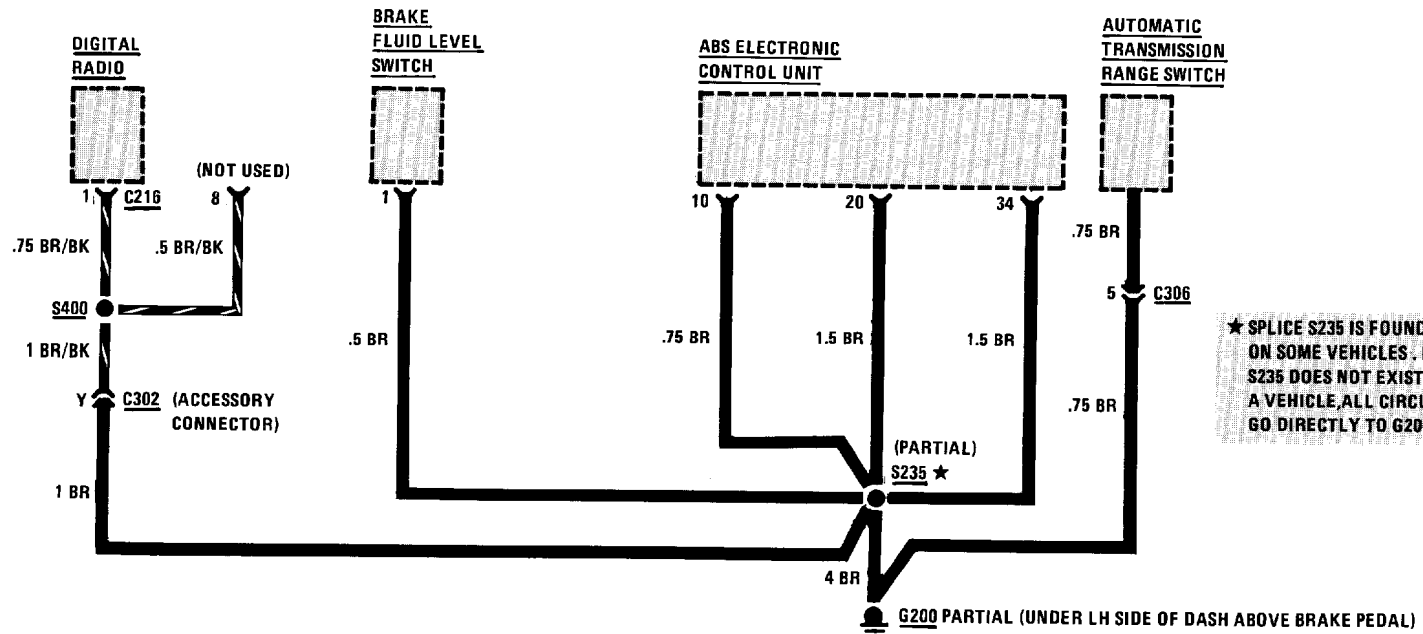
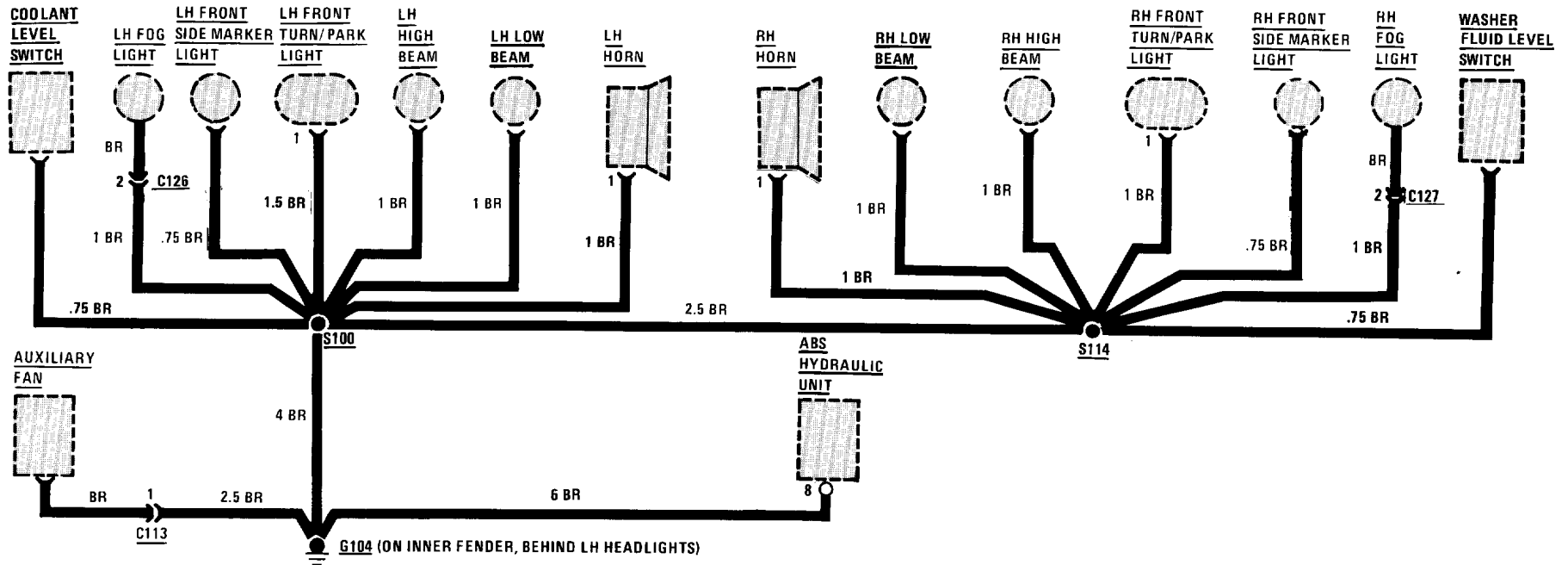

★ SPLICE S235 IS FOUND ON SOME VEHICLES. IF S235 DOES NOT EXIST ON A VEHICLE, ALL CIRCUITS GO DIRECTLY TO G200.

0670-16 POWER DISTRIBUTION

GROUND DISTRIBUTION: G202 AND G300

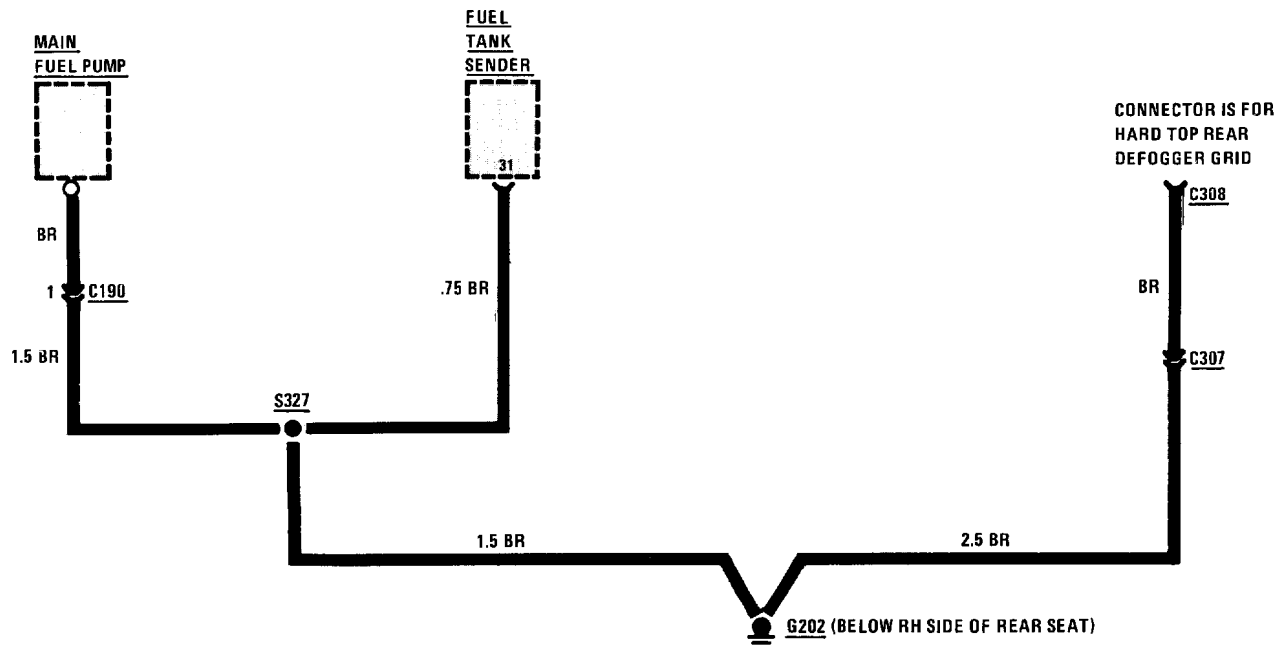
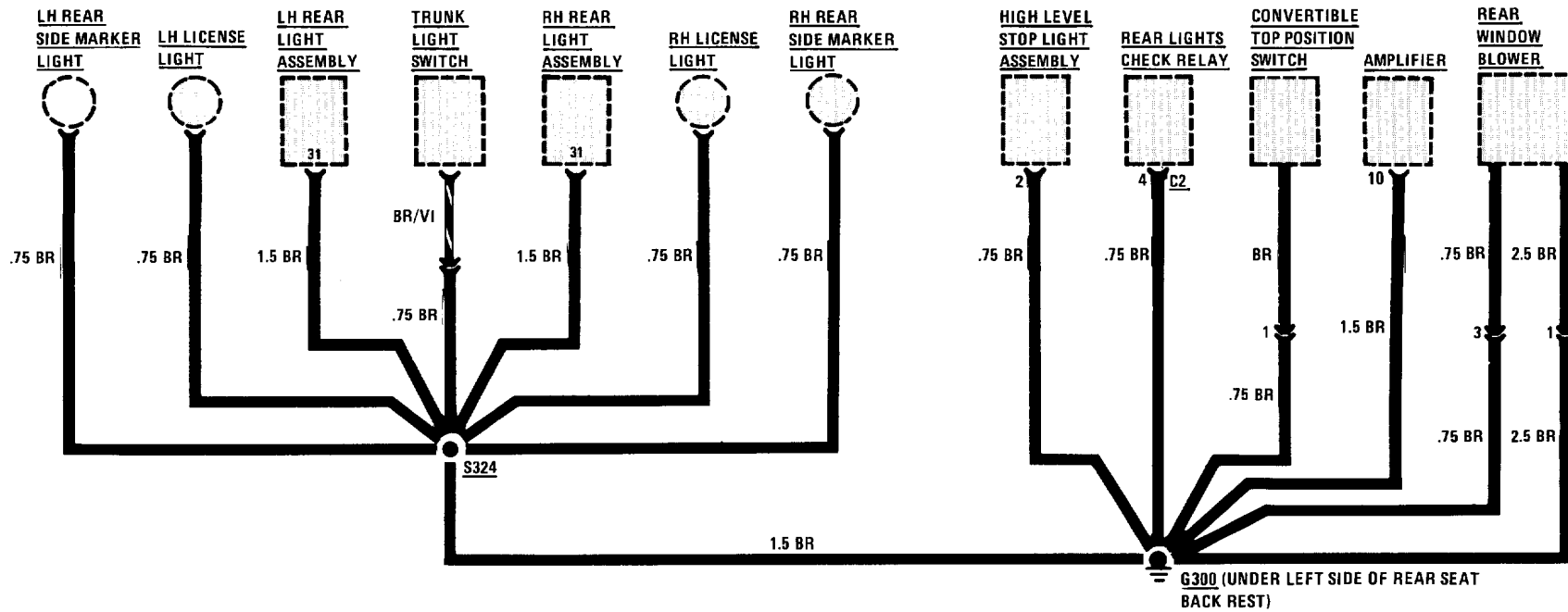

GROUND DISTRIBUTION: G303 AND G304

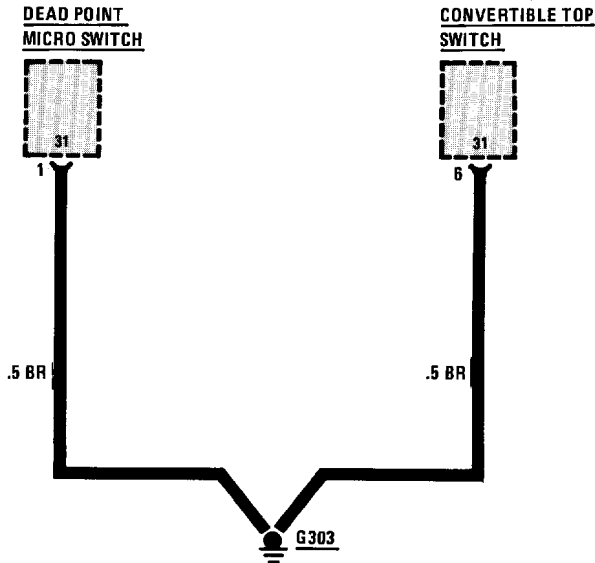
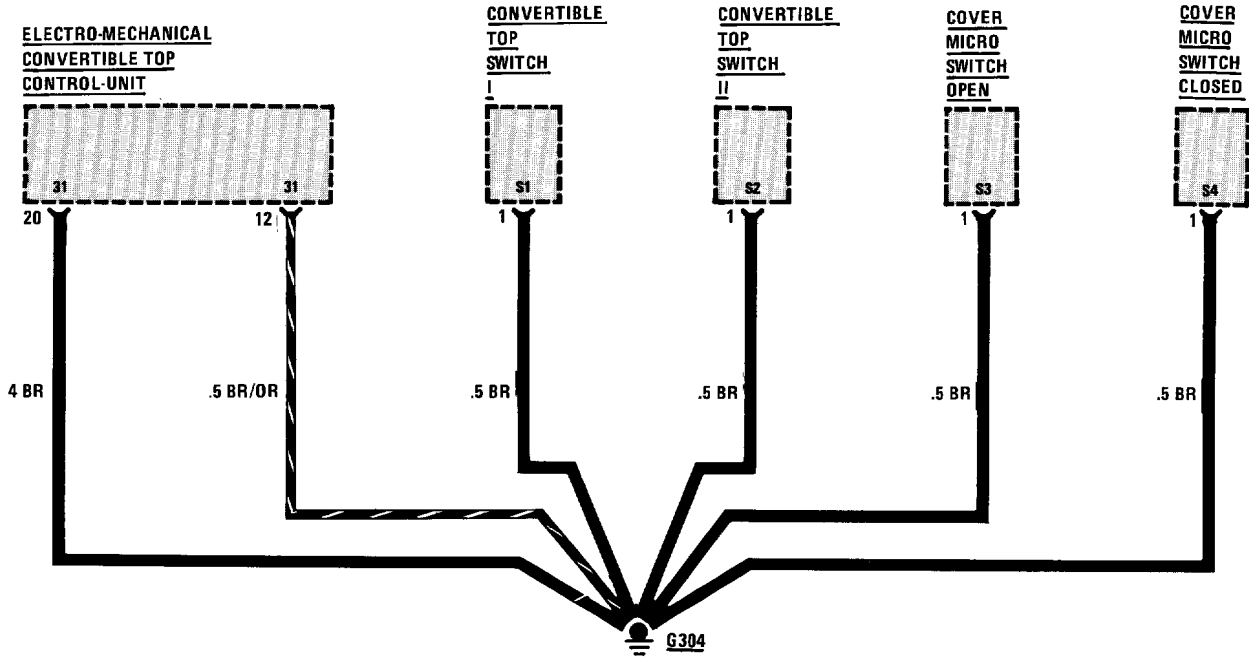

1360-8 INJECTION ELECTRONICS

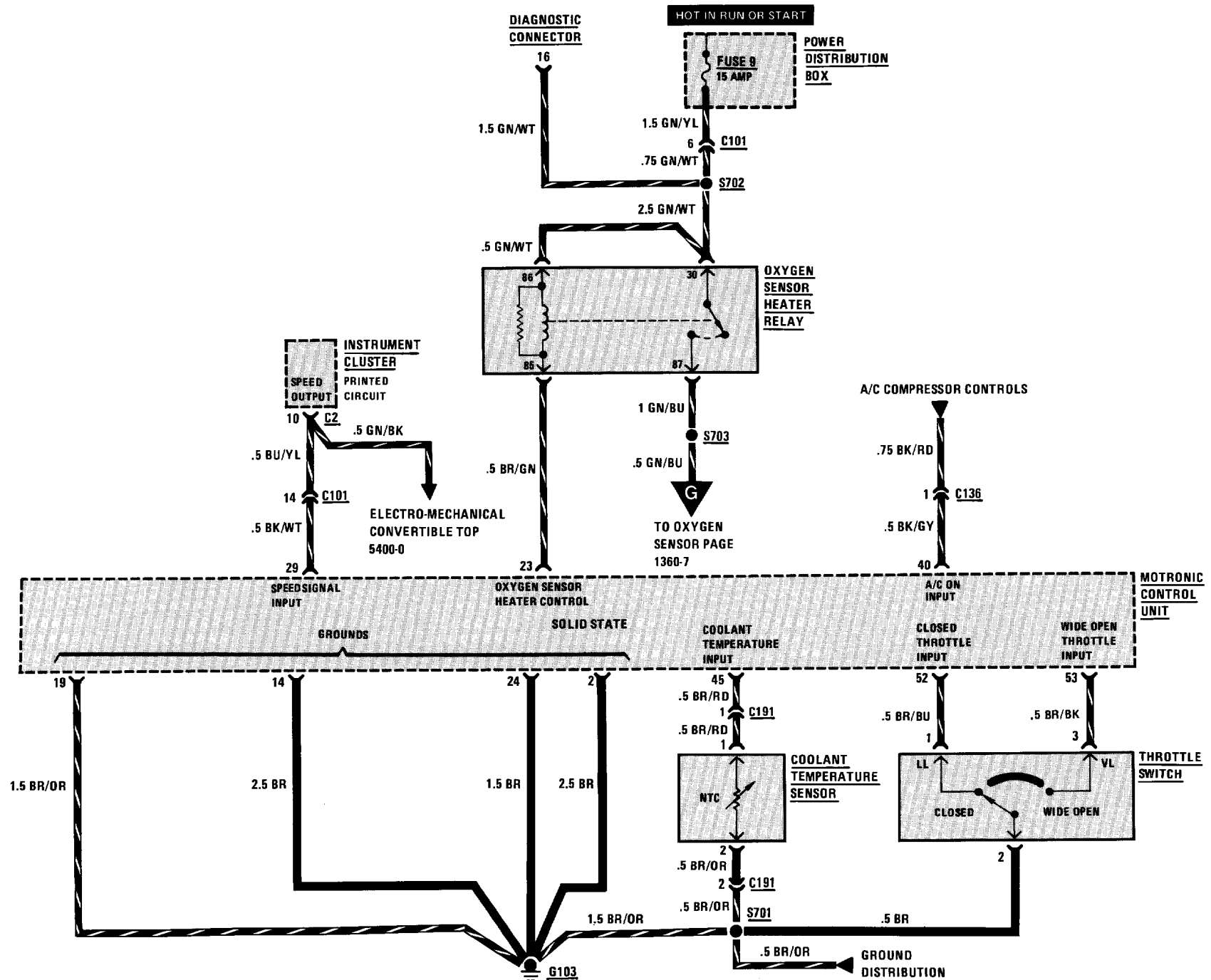

3234-0 SUPPLEMENTAL RESTRAINT SYSTEM (SRS)

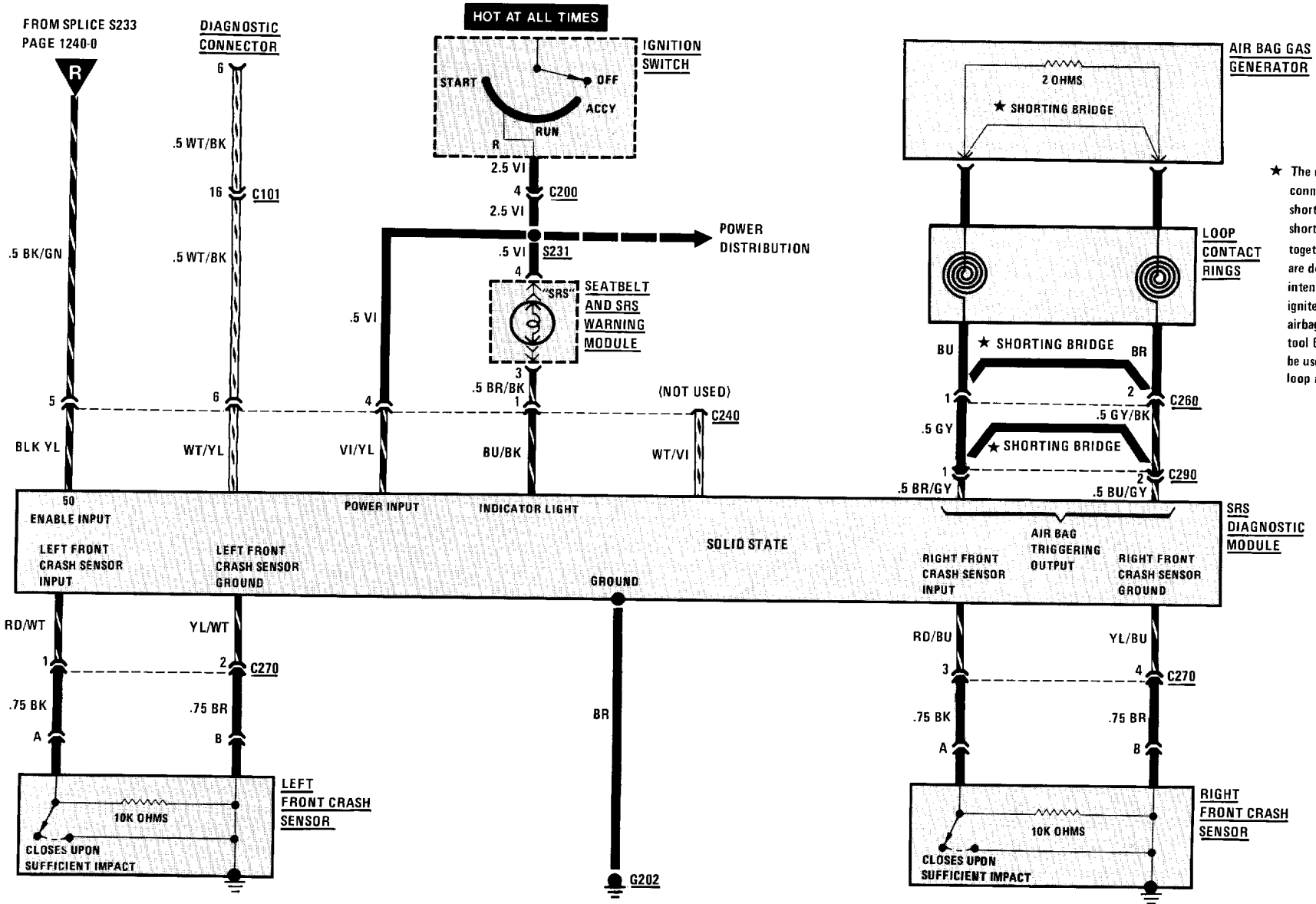

★ The driver's airbag generator connectors are fitted with shorting bridges. The bridges short the generator leads together when the connectors are demated to prevent unintentional triggering of the igniter, when working on the airbag system. Only special tool 62 1260 (test lead) may be used to check the wire loop and igniter resistance.

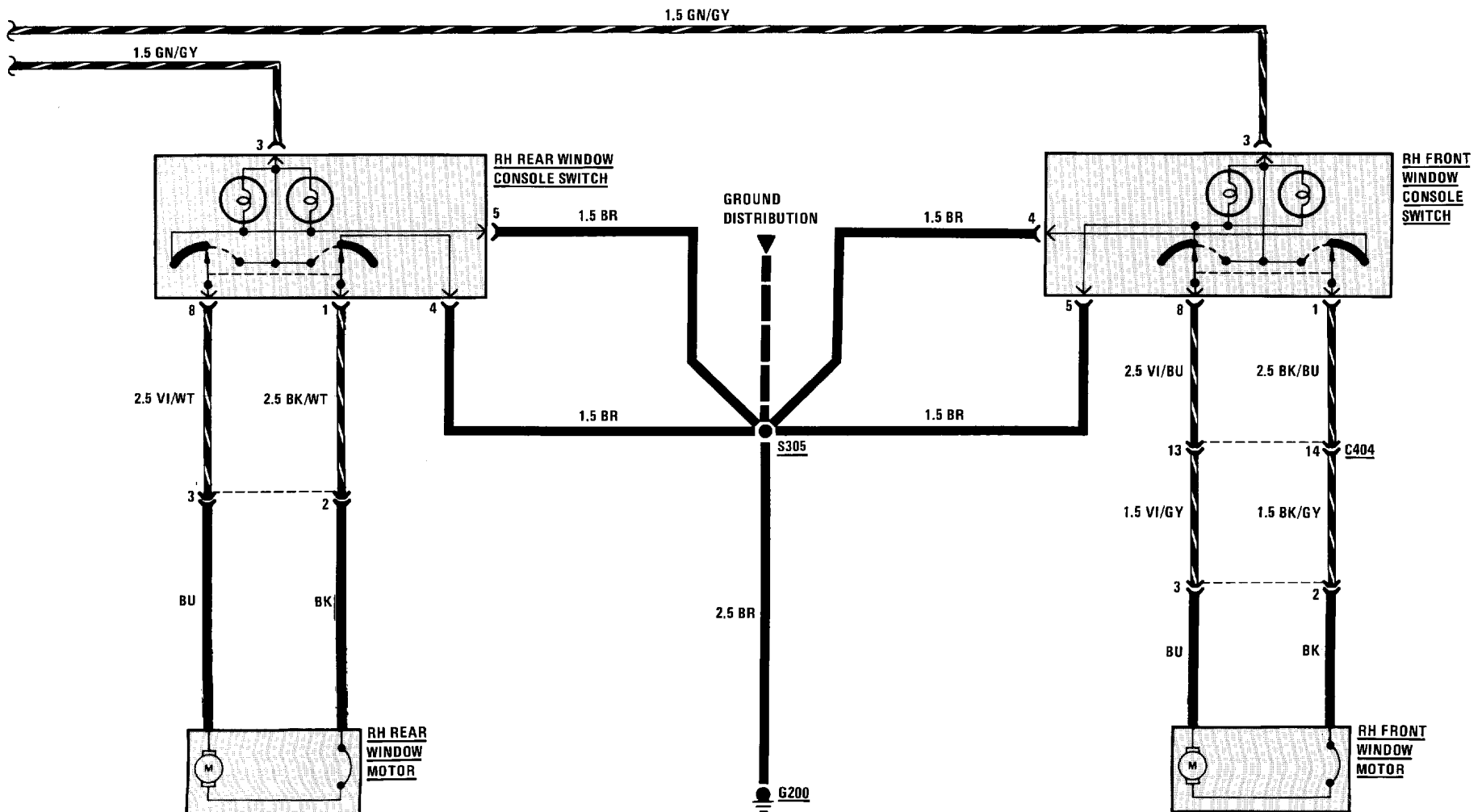

HEATED SEATS

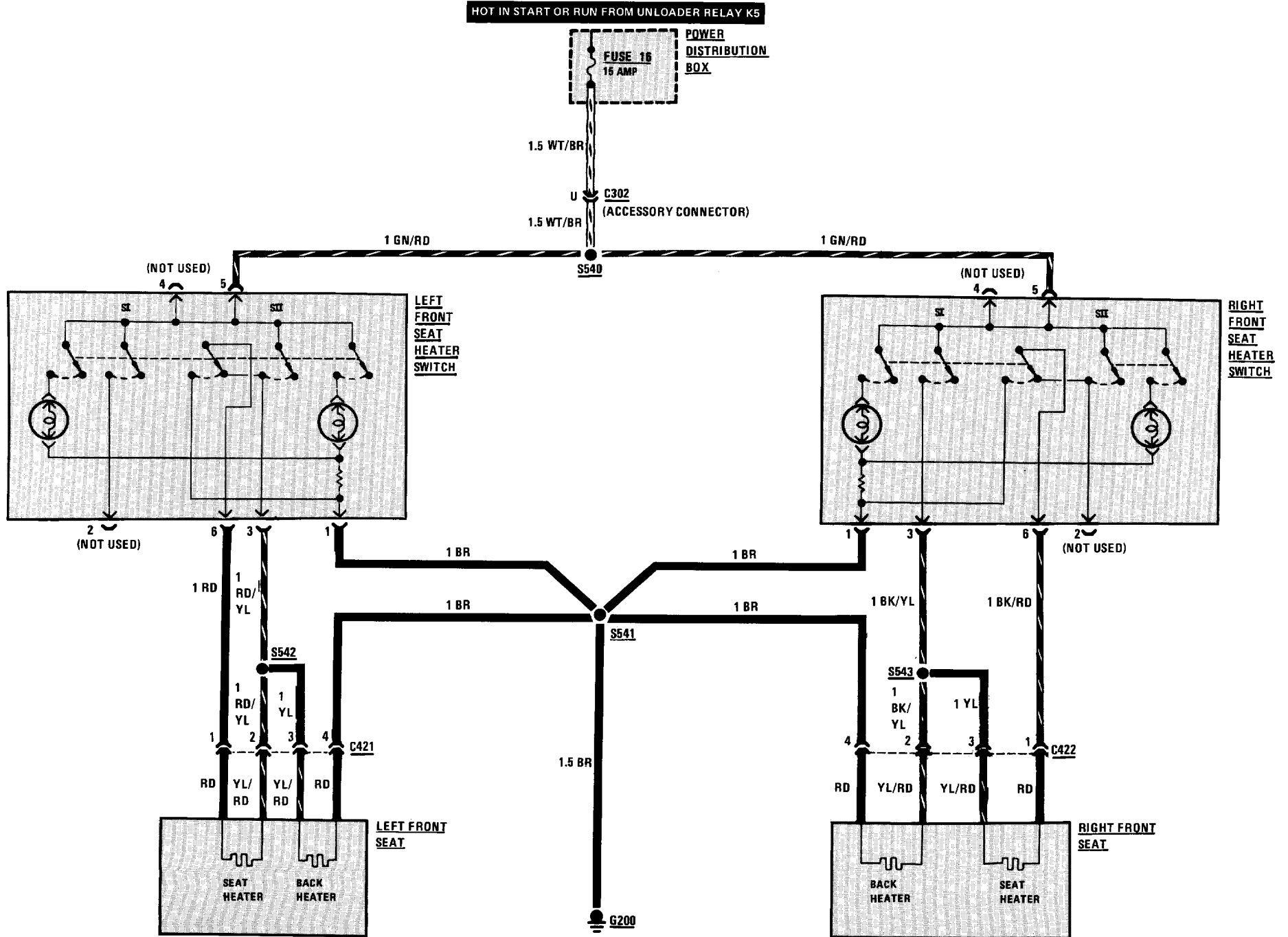

5400-0 ELECTRO-MECHANICAL CONVERTIBLE TOP

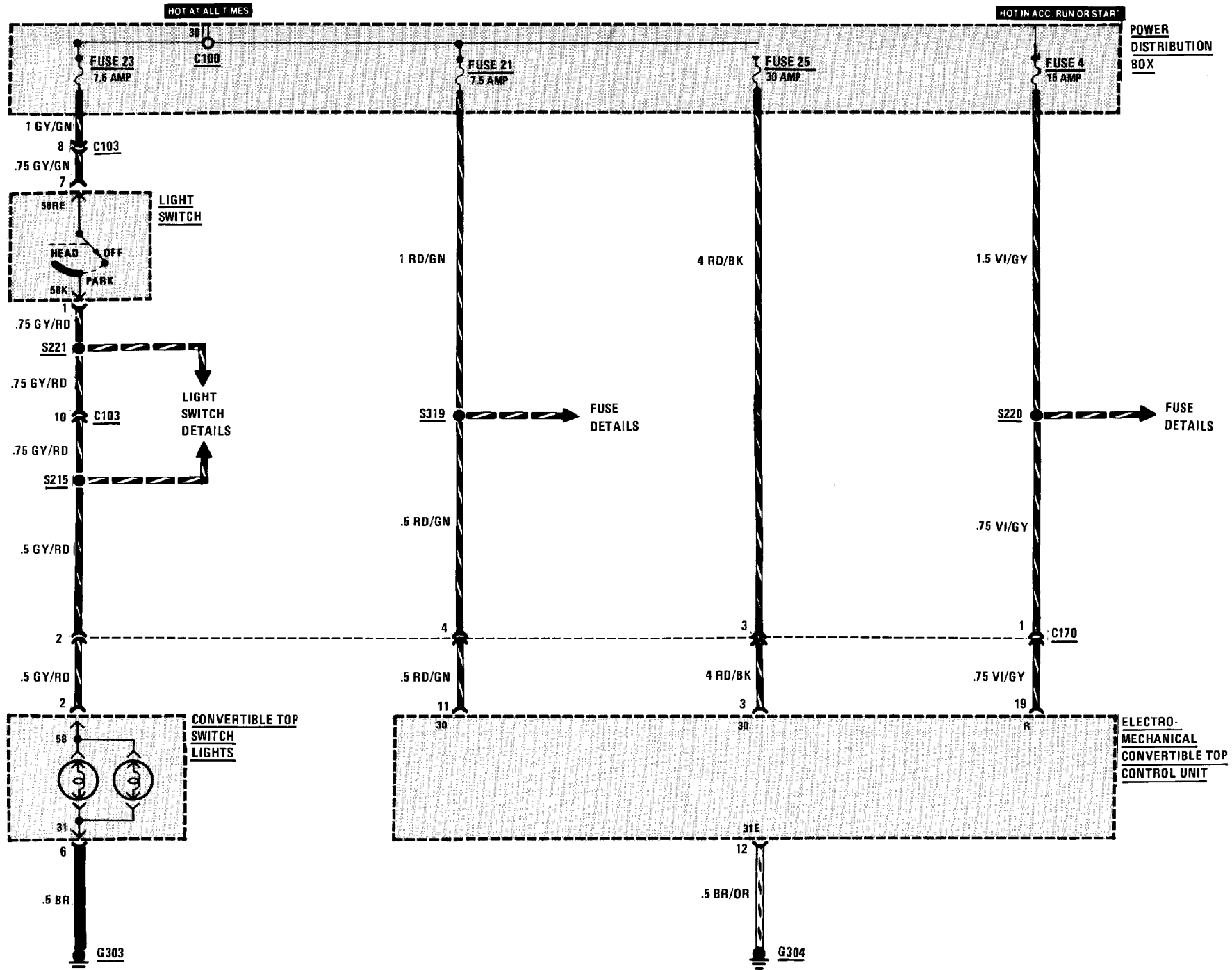

ELECTRO-MECHANICAL CONVERTIBLE TOP 5400-1

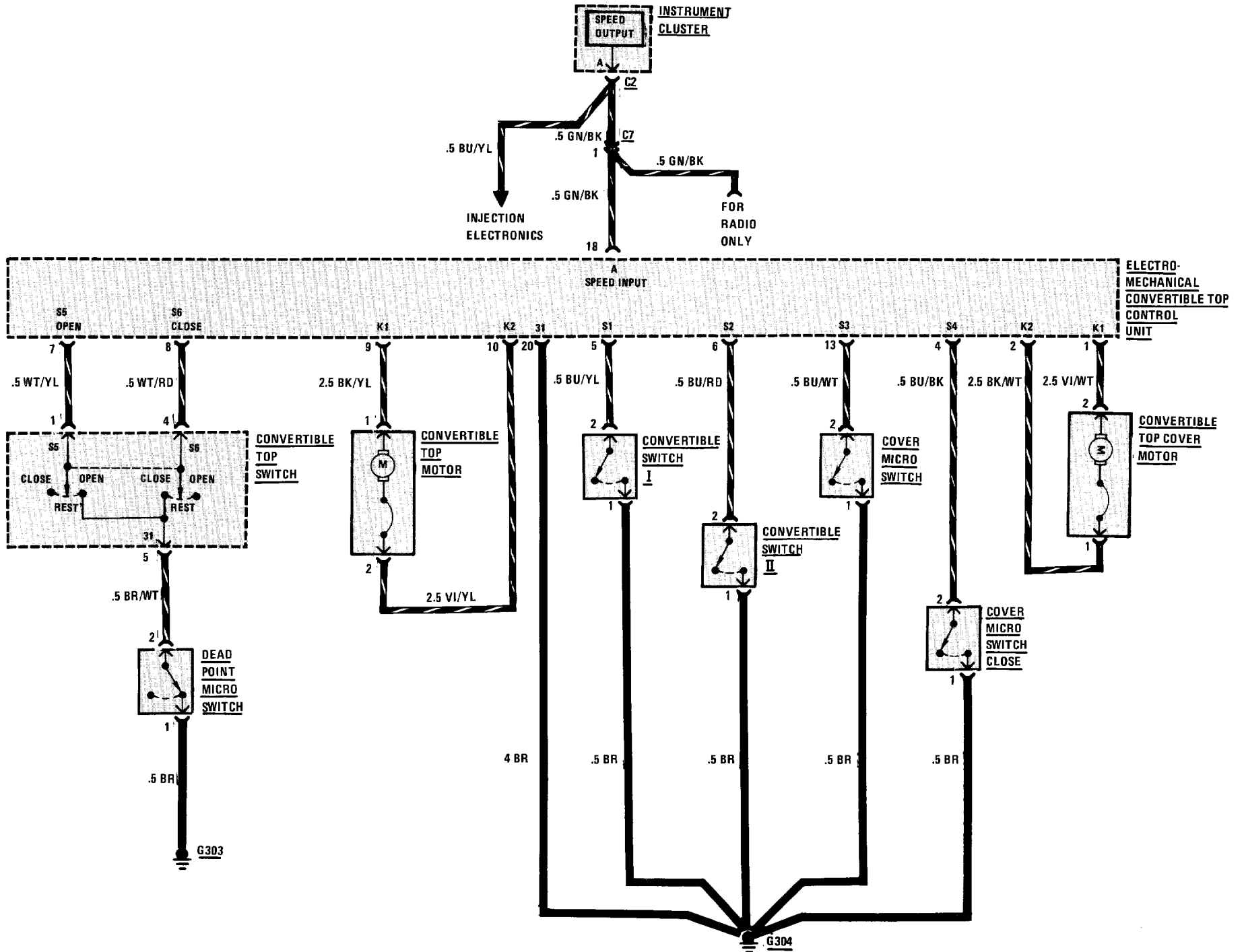

6210-0 INSTRUMENT CLUSTER

SPEEDOMETER/INDICATORS

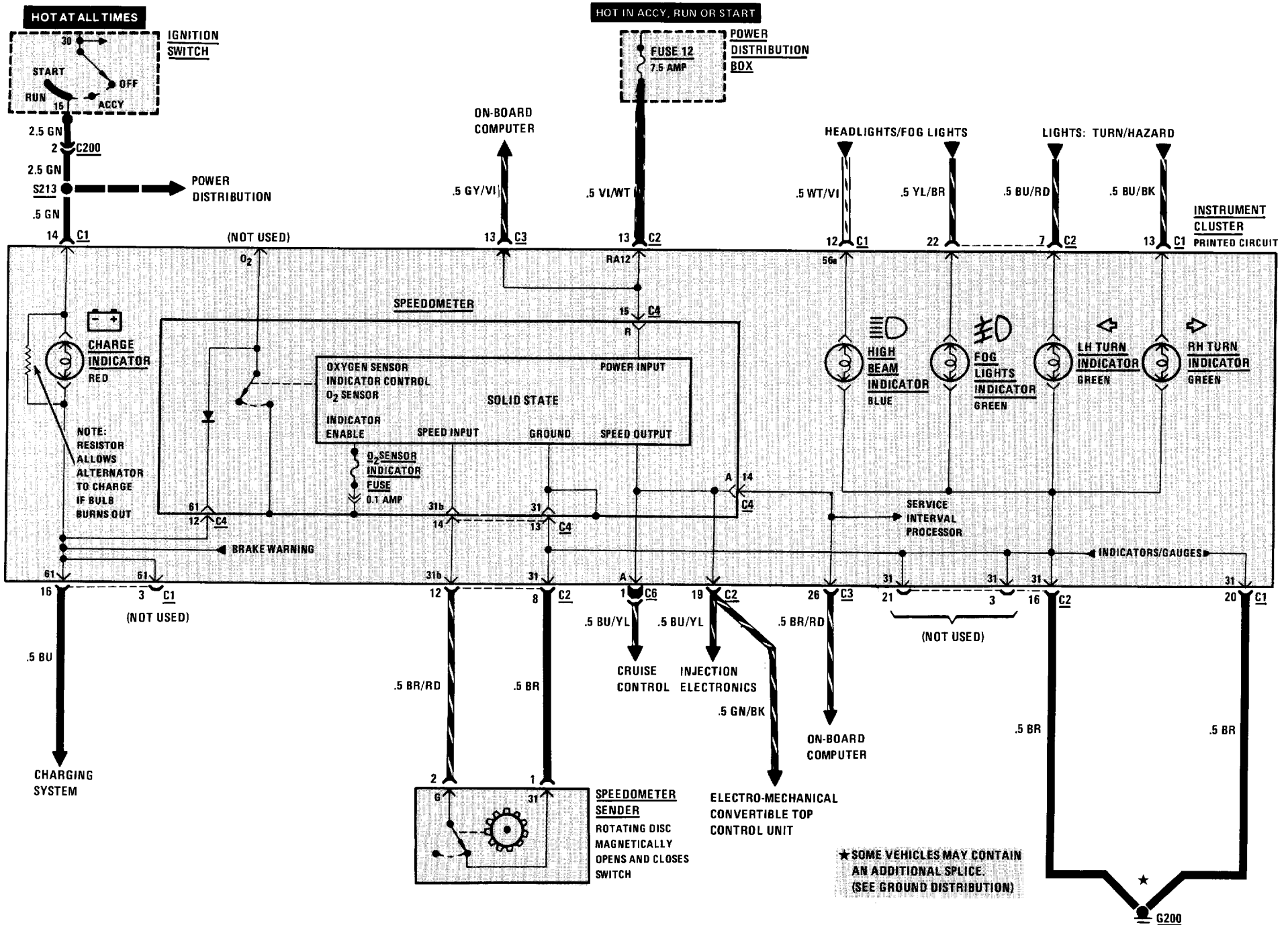

ACTIVE CHECK CONTROL

1. When the Ignition Switch is initially placed in RUN, the Active Check Control Arm Indicator flashes, and the Active Check Control Unit Brake Light LED and panel light illuminate for test purposes. Depressing the brake pedal clears the display.
2. When the Ignition Switch is placed in "Run," fault monitoring begins. To monitor the low beams, rear lights, or license lights, those circuits must be on. The brake lights are monitored only while the brake pedal is depressed. An exception to this is when all Brake Light Circuits are open a fault will be indicated with the Ignition Switch in RUN.
3. When a fault occurs, the alarm indicator flashes, the appropriate LED fault indicator lights, and the panel light goes on for five seconds. Depressing the check button will clear the alarm indicator, but the LED fault indicator remains on.
4. To test the unit, depress the test button. The LED fault indicators and the panel lights should go on.

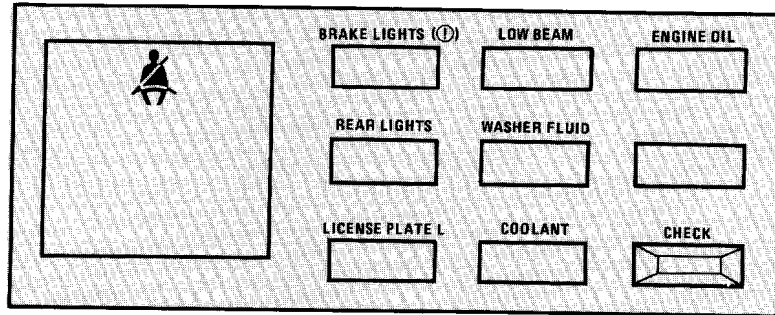
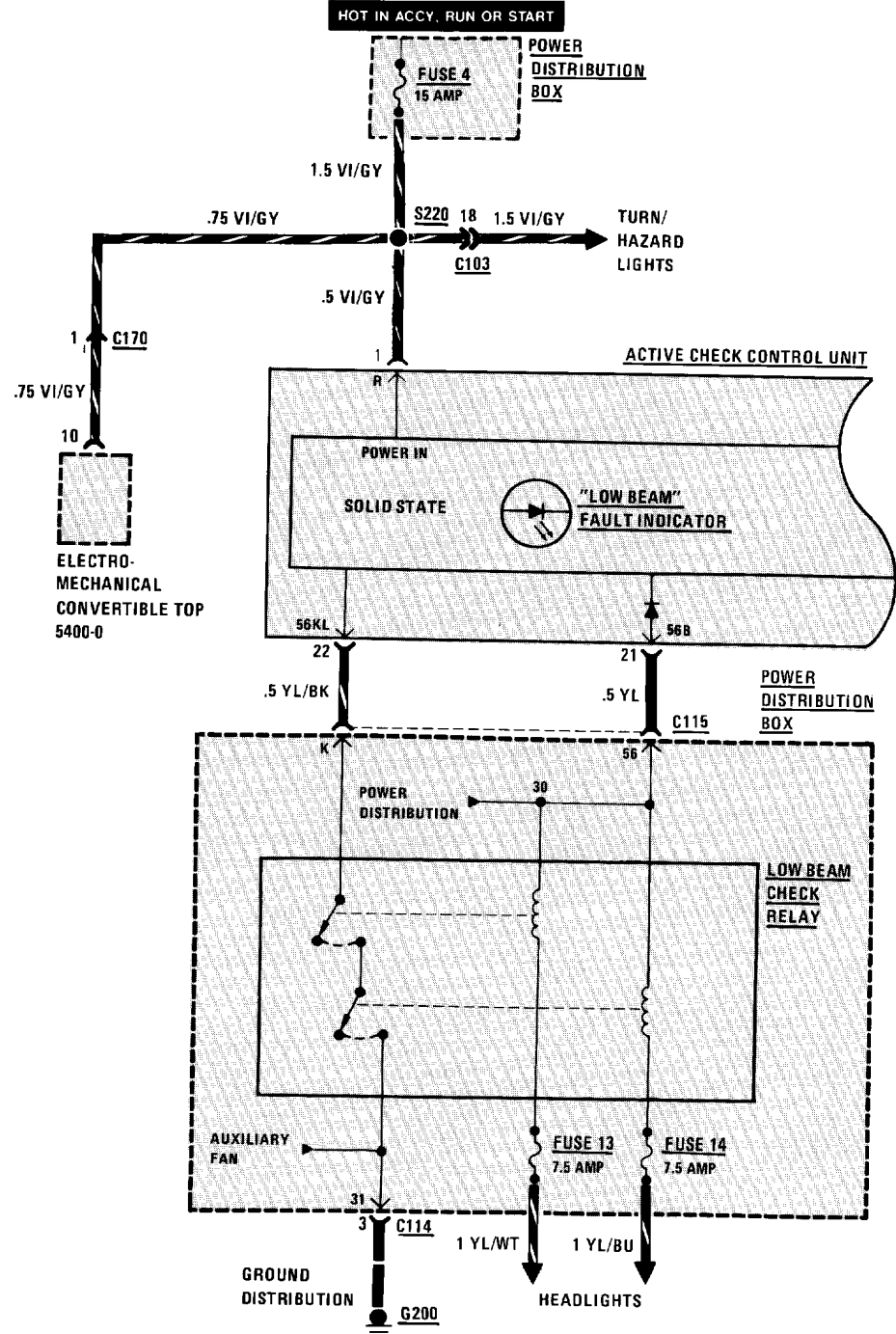
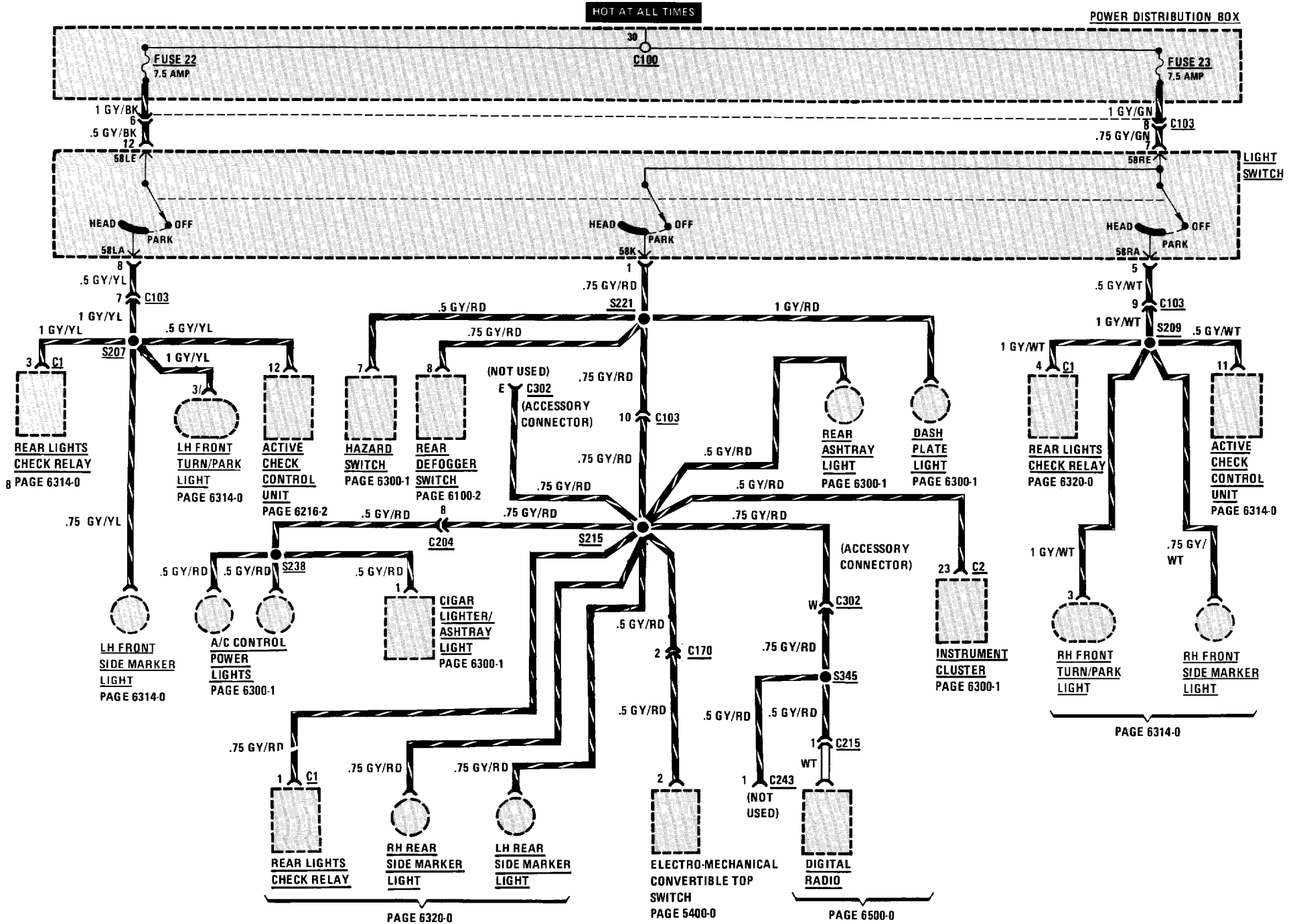
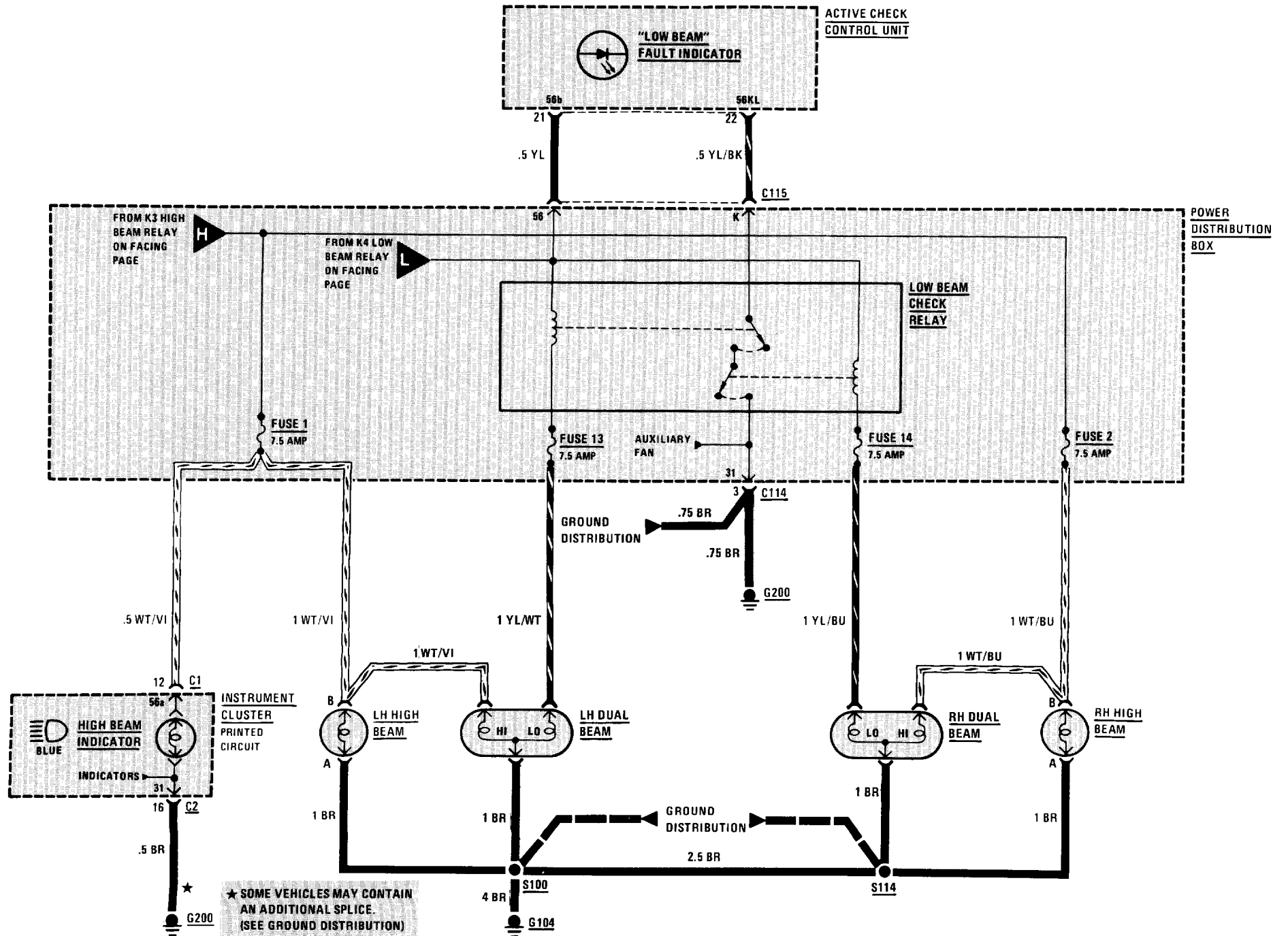

Figure 1 - Active Check Control Unit Above Rear View Mirror



6300-0 LIGHT SWITCH DETAILS





6313-0 TURN/HAZARD LIGHTS

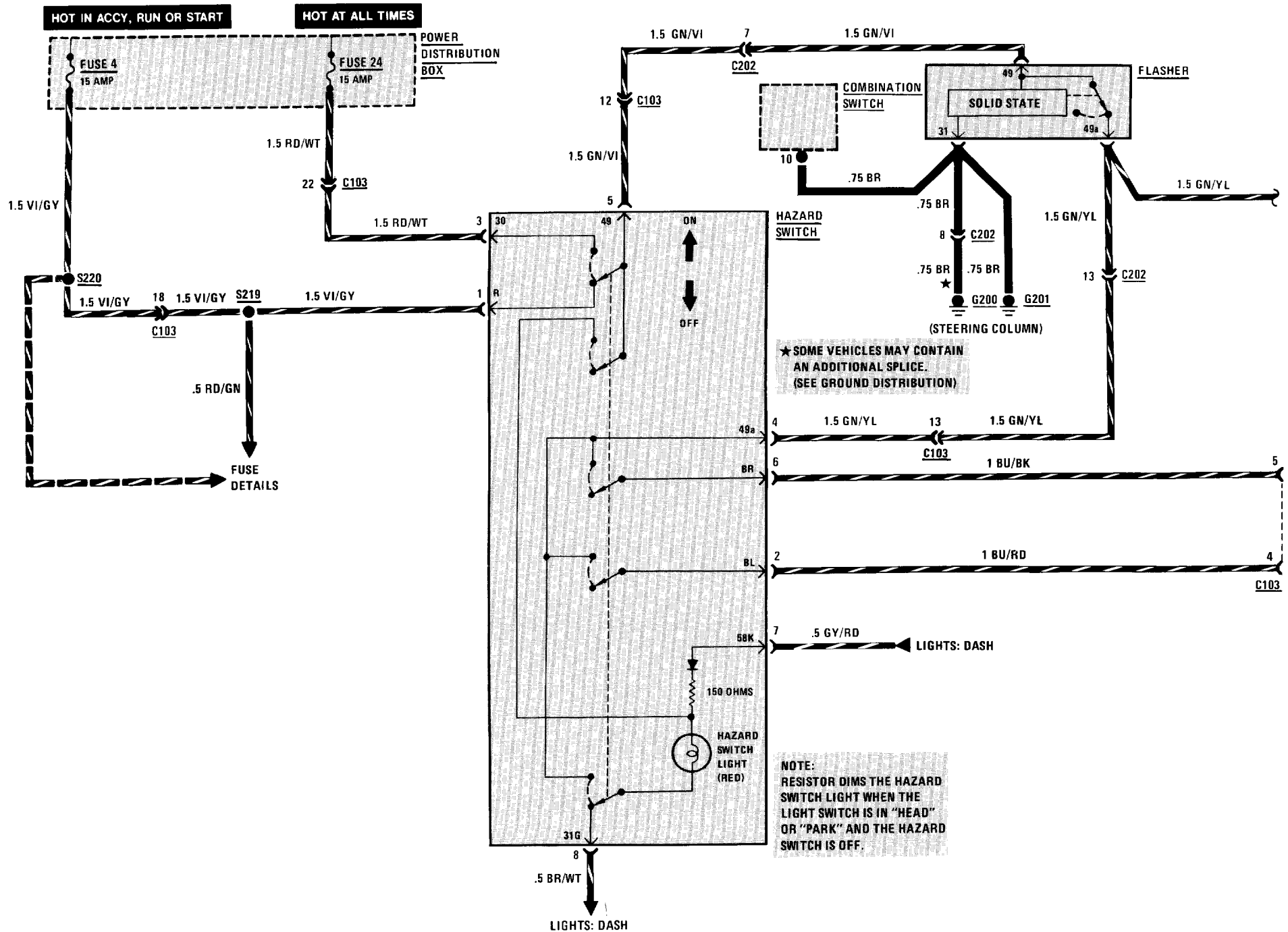

6322-0 BACK UP LIGHTS

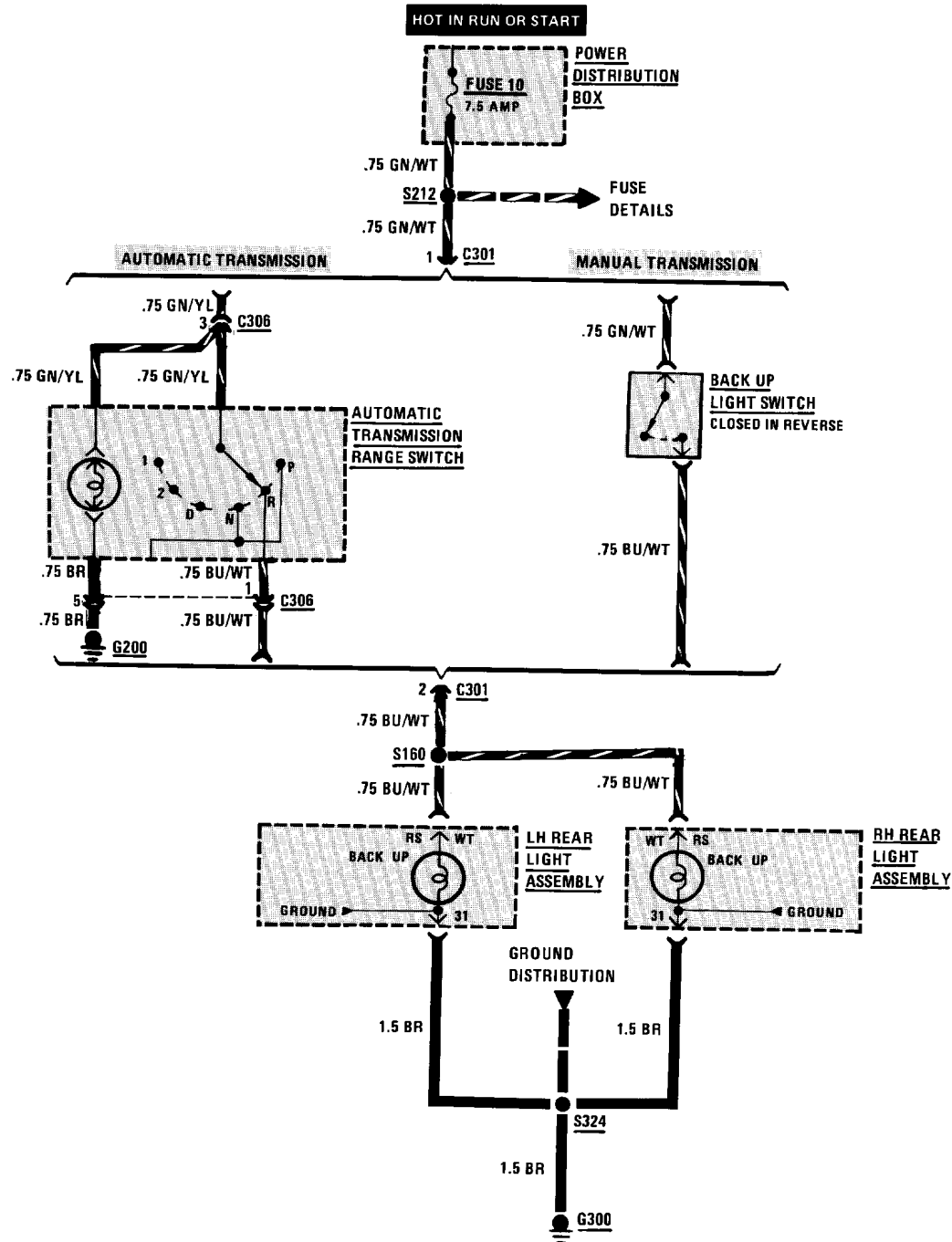

6330-0 INTERIOR LIGHTS

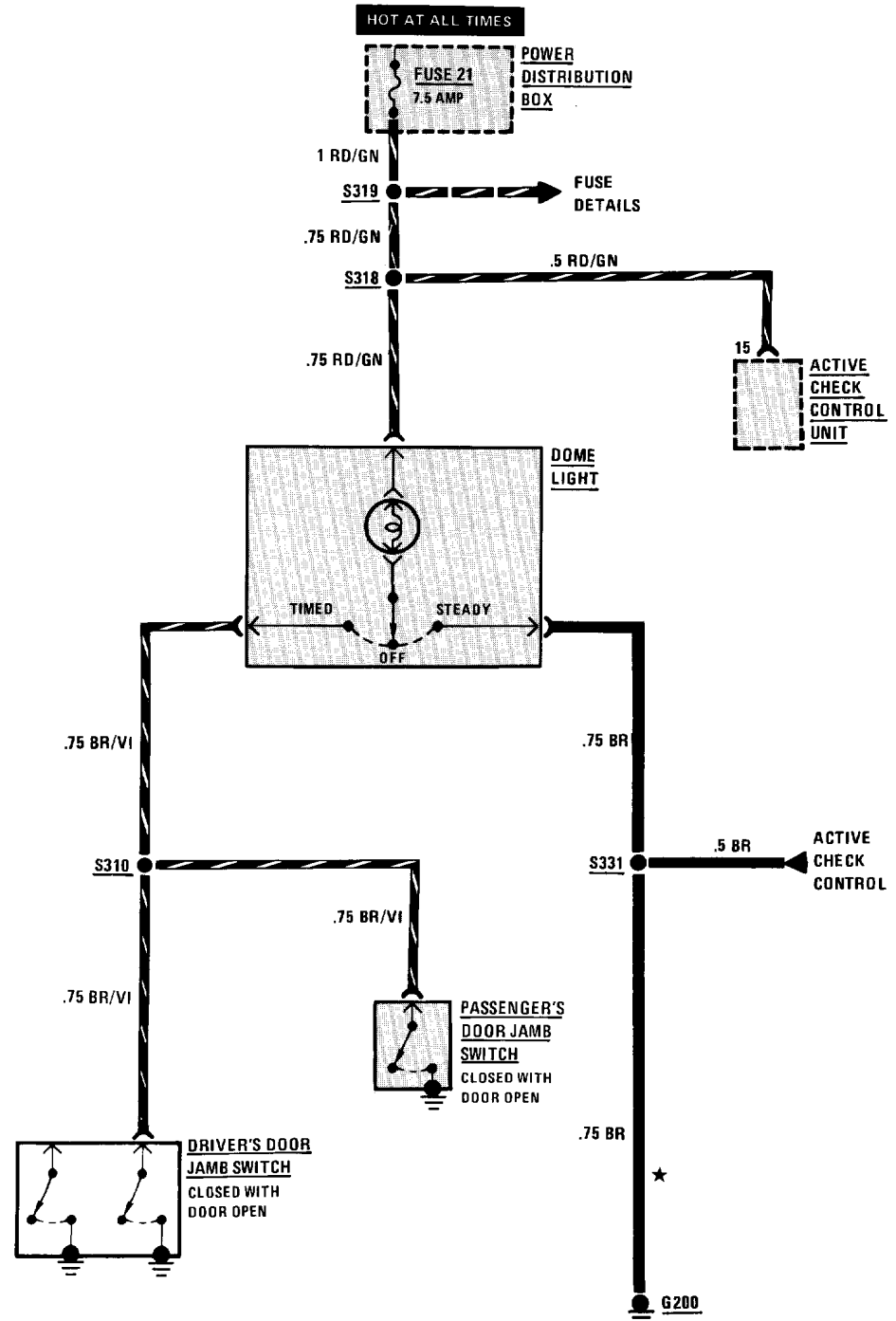

★ SOME VEHICLES MAY CONTAIN AN ADDITIONAL SPLICE. (SEE GROUND DISTRIBUTION)

HEATING AND AIR CONDITIONING (COMPRESSOR CONTROLS)

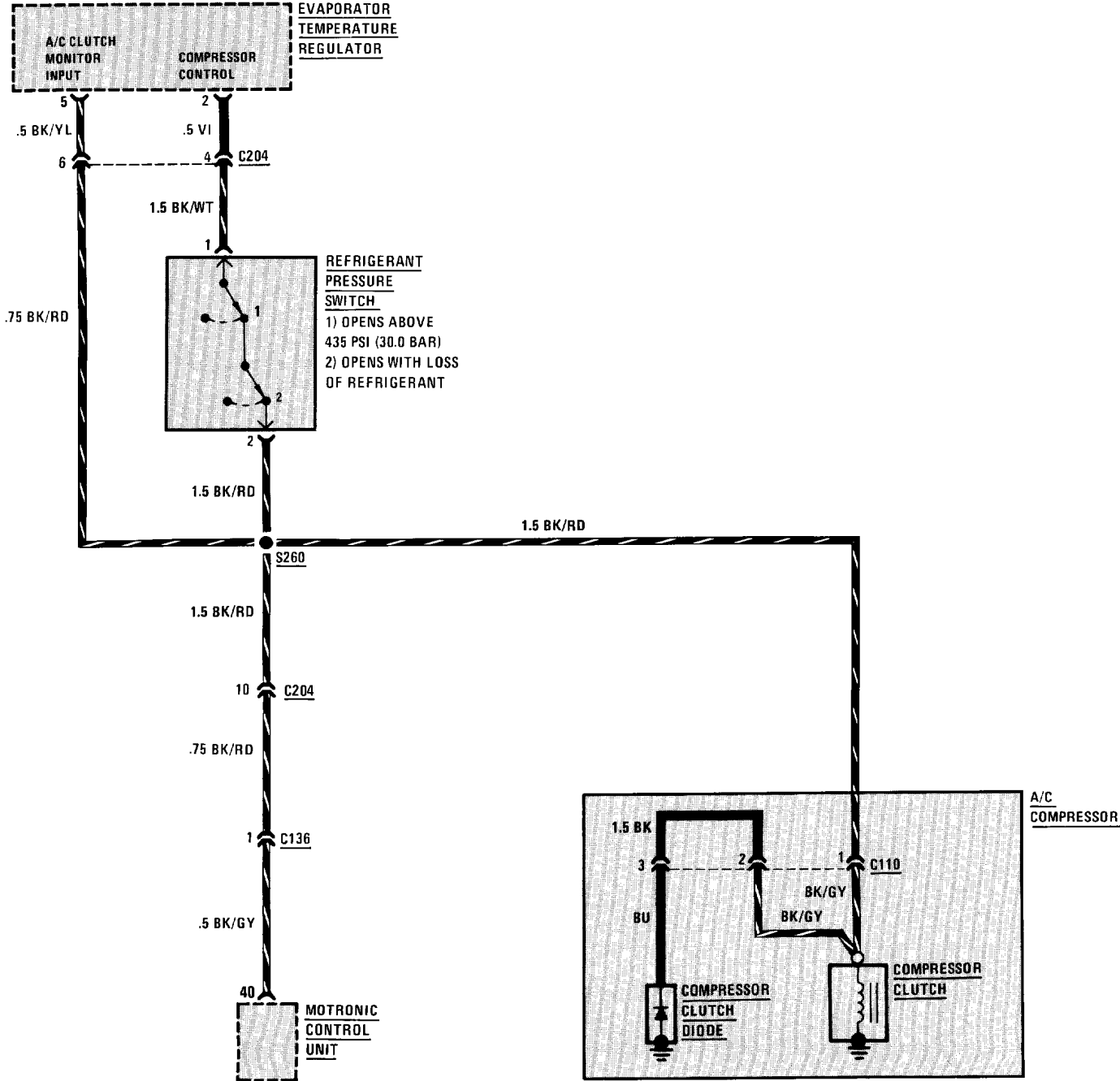

8000-0 SPLICE LOCATION VIEWS

SPLICE LOCATION INDEX

This index contains all the splices in the car, what harness each one is in, and the page that the splices appear on. The drawings after the index show how the harness is routed through the car and where the splices are located on the harness.

SPLICE	HARNESS	PAGE NUMBER	SPLICE	HARNESS	PAGE NUMBER
S100	MAIN	8000-2	S229	AIR CONDITIONING	NOT SHOWN
S101	ENGINE	8000-3	S230	MAIN	8000-2
S104	ENGINE	8000-3	S231	MAIN	8000-2
S105	ENGINE	8000-3	S232	MAIN	8000-2
S106	ENGINE	8000-3	S233	MAIN	8000-2
S107	ENGINE	8000-3	S234	MAIN	8000-2
S108	ENGINE	8000-3	S235	MAIN	8000-2
S109	ENGINE	8000-5	S236	MAIN	8000-2
S111	ENGINE	8000-3	S237	MAIN	8000-2
S112	ENGINE	8000-3	S239	MAIN	8000-2
S113	ENGINE	8000-3	S240	AIR CONDITIONING	NOT SHOWN
S114	MAIN	8000-2	S250	AIR CONDITIONING	NOT SHOWN
S115	MAIN	8000-2	S251	AIR CONDITIONING	NOT SHOWN
S116	MAIN	8000-2	S252	AIR CONDITIONING	NOT SHOWN
S118	MAIN	8000-2	S260	MAIN	8000-2
S119	MAIN	8000-2	S300	DOOR	8000-4
S120	ENGINE	8000-3	S301	DOOR	8000-4
S160	REAR BACK UP LIGHTS	8000-2	S302	DOOR	8000-4
S201	ON-BOARD COMPUTER	8000-6	S303	DOOR	8000-4
S202	ON-BOARD COMPUTER	8000-6	S305	DOOR	8000-4
S207	MAIN	8000-2	S306	INSTRUMENT PANEL	8000-5
S209	MAIN	8000-2	S307	INSTRUMENT PANEL	8000-5
S210	MAIN	8000-2	S308	DOOR	8000-4
S211	MAIN	8000-2	S309	DOOR	8000-4
S212	MAIN	8000-2	S310	MAIN	8000-2
S213	MAIN	8000-2	S312	MAIN	8000-2
S215	MAIN	8000-2	S313	MAIN	8000-2
S219	INSTRUMENT PANEL	8000-5	S316	MAIN	8000-2
S220	MAIN	8000-2	S319	DOOR	8000-2
S221	INSTRUMENT PANEL	8000-5	S322	DOOR	8000-4
S228	CRUISE CONTROL	NOT SHOWN			

8000-2 SPLICE LOCATION VIEWS

MAIN HARNESS SPLICE LOCATIONS

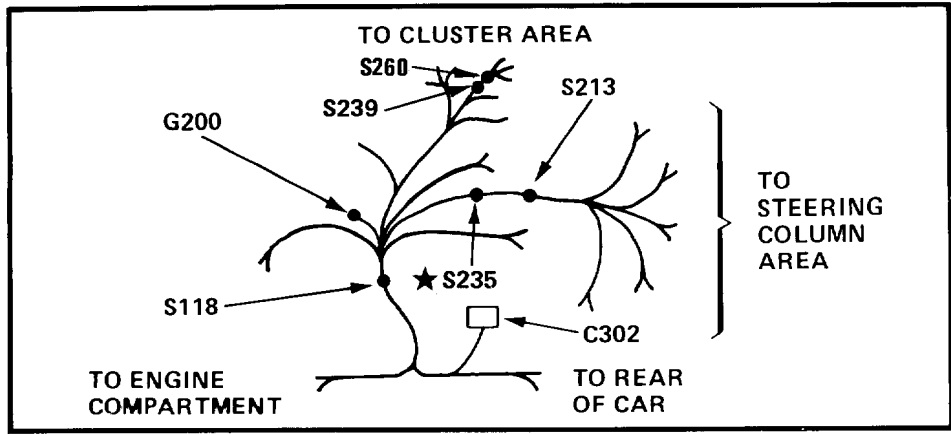

★ S235 MAY NOT EXIST ON ALL VEHICLES

S330
S329
S327

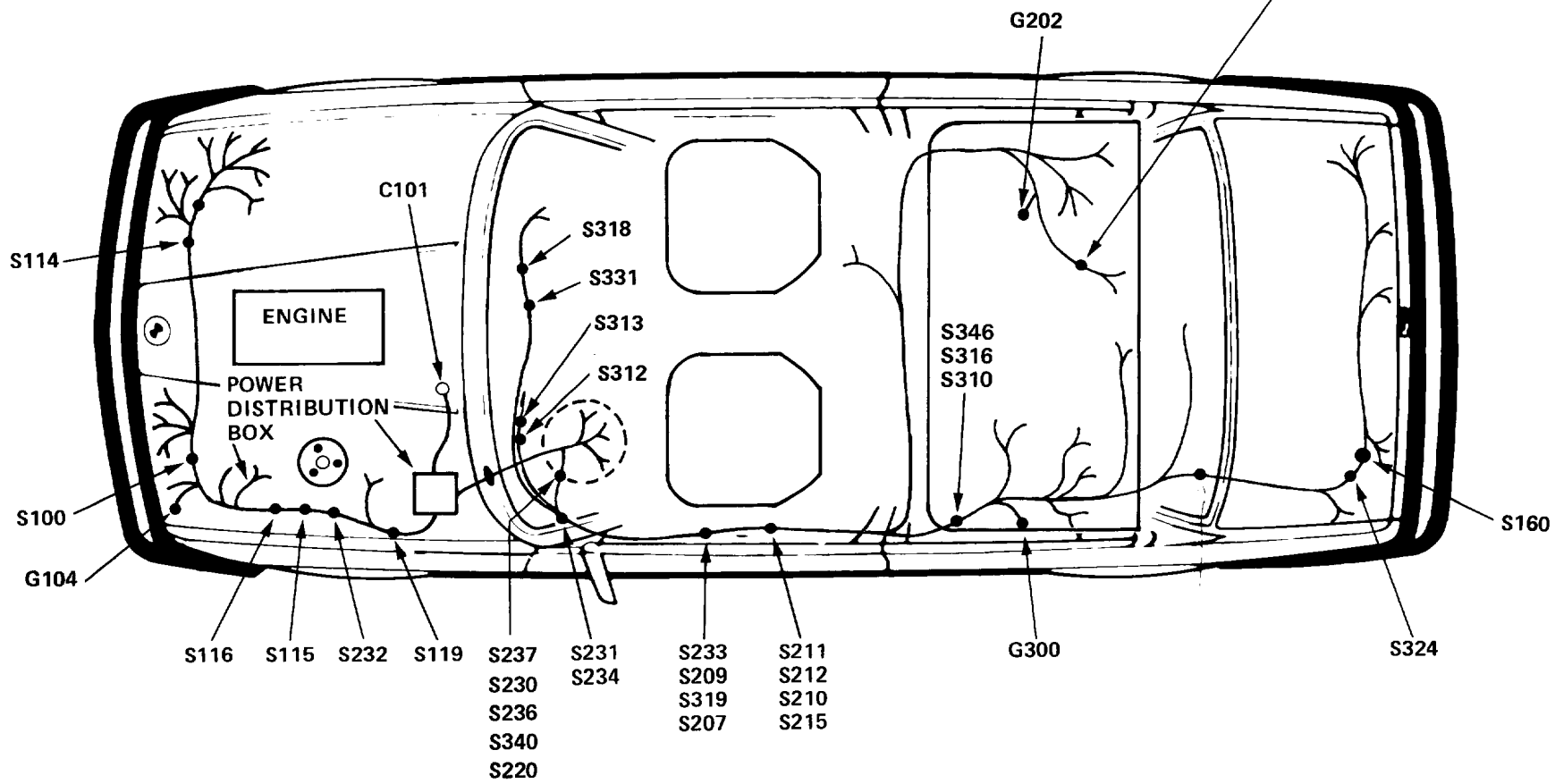

CIRCUITS USING C302 (ACCESSORY CONNECTOR)

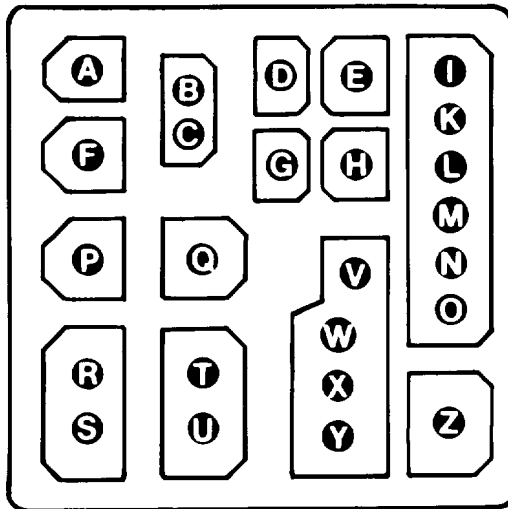

Figure 1-C302 (Accessory Connector)
Front View—Under LH Side
of Dash Ahead of Pedal Assembly

TERMINAL	CIRCUIT	TERMINAL	CIRCUIT
A	Not Used	N	Not Used
B	Not Used	O	Not Used
C	Not Used	P	Not Used
D	Central Locking	Q	Power Windows
E	Not Used	R	Cruise Control
F	Not Used	S	Cruise Control
G	Not Used	T	Not Used
H	Board Computer	U	Heated Seats
I	Not Used	V	Radio
J	Not Used	W	Radio
K	Not Used	X	Radio
L	Not Used	Y	Radio, Ground
M	Not Used	Z	Power Antenna

B060025



Wiring Face

C240

B060003 03

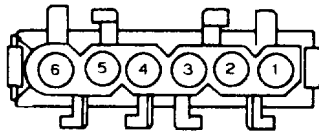

Mating Face

C242

B080002.00

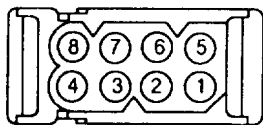

Mating Face

C243

B030001.01

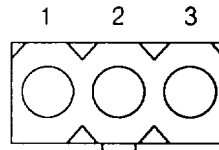

Wiring Face

C303

C304

6

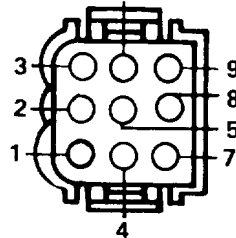

Wiring Face

C306

B050011.00

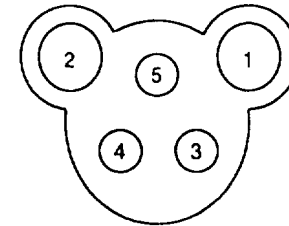

Wiring Face

C413

B040004.00

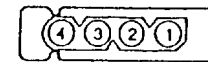

C421

C422

C170

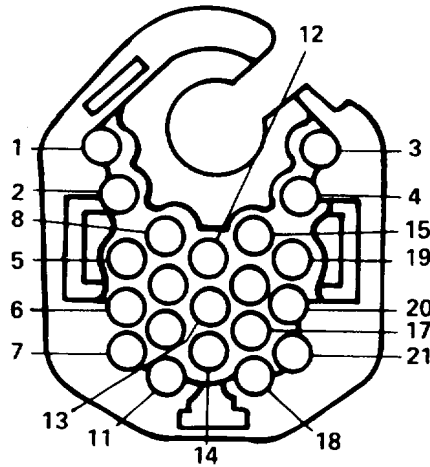

Wiring Face

C404

C405

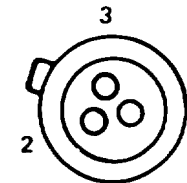

Wiring Face

C503